

STAGEMAKER

Next level partnership

new
SL

IP66

as standard
for
SL5 & SL10

D8+

as standard
SQP2





STAGEMAKER
SLS DOUBLE BRAKE

STAGEMAKER

STAGEMAKER SL is the result of our vast experience in the entertainment market, along with well established R&D and relationships with our worldwide customer base.

1975



Launch of Europe's first inverted, electric powered hoist, the LITACHAIN L104 range

1990



Launch of the LITACHAIN LI 5 & LI10 range

1998



Launch of the STAGEMAKER SM range

2013



Launch of the STAGEMAKER SR range

2020



Launch of the STAGEMAKER SL range

STAGEMAKER has an excellent global reputation with more than 45 years of experience in the entertainment rigging market as well as theaters, studios, events, trade show,... Our long life span, together with our impressive customer references, proves our commitment to this market and the reliability and ingenuity of our products.

Backed by this ongoing policy of innovation, constant upgrading in tune with current technologies and worldwide regulation (CE, DIN), the STAGEMAKER SL range of hoists will further prove that Stagemaker is Raising the Standard of Performance in the entertainment market.

STAGEMAKER

SL

new

+ innovation

PERFECT PUSH

- > New "Perfect Push MKII", patented concept, 5 pocket load wheel. This innovation provides improved chain guiding and chain flow, to help reduce the risk of chain jamming.



IP66
as standard
for
SL5 & SL10

D8+
as standard
SQP2

+ safety

- > Stagemaker SL & SR is **D8+ as standard** (SQP2) and D8 by removing one brake.
- > **Double lifting brake as standard** for more safety.
- > **IP66 protection as standard** for the entire hoist.
- > Clutch concept. The clutch position in the reducer ensures the load is held by the brake regardless of the machine's daily operating conditions.
- > Magnetic limit switch as standard on all SL5 and SL10 (version B) with standard Limitflux.
- > **G100 Black electro galvanized lifting chain as standard** manufactured specifically for Stagemaker.
- > All hoist motor as integral thermal protection to prevent overheating (version B).

Optional equipment

- > Single brake.
- > Pushbutton controller.
- > 4, 8, 12,... channels controllers.
- > Low voltage control (48 V) version B.
- > Large range of flight cases.
- > Non rotating hook.
- > Suspension bracket instead of upper hook.
- > Industrial chain guide.
- > Encoder.
- > Load measuring system.
- > Rain cover protection.



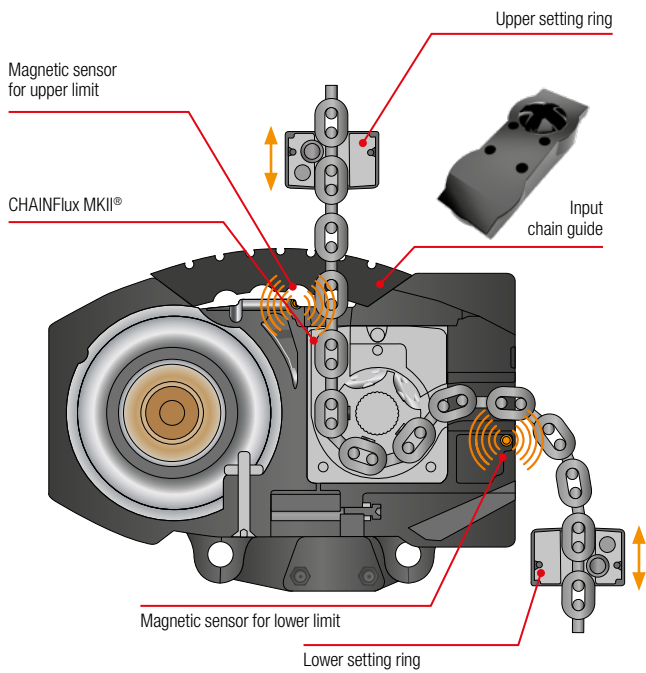

CHAINFLUX®

- > Design provides a horizontal flow of the chain as it comes off the load wheel. This design, along with the high strength aluminum construction, allows for a more fluid flow of the chain into the chain bag and helps to reduce the risk of chain jamming. Drain in housing to avoid water collection in load wheel compartment.



LIMITFLUX®

- > The Limitflux is a built-in limit switch device in the CHAINFlux MKIII that's allow to control setting of hoist or hook position in industrial suspension or climbing configuration.
- > Accuracy of the system is given at one link of lifting chain.
- > The setting of the limit is operated by two magnetic ring (upper and lower) which can be easily moved and set along the lifting chain.

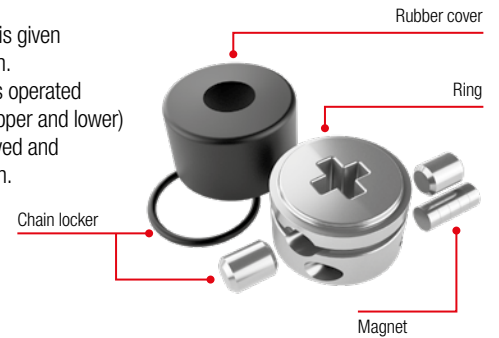

+ operating convenience

- > Operating sound level down to 60 db (test certificate available).
- > Climbing hoist or industrial suspension configuration can be changed simply by reversing the chain container.
- > Rotating upper and lower hooks.
- > High capacity and high strength chain bag made of 1100 denier, high grade black fabric, is both removable and reversible.
- > Rubber buffers located on the hoist corners provide added protection for the hoist.
- > Motor design provides consistent speeds when both fully loaded or unloaded.
- > Electrical components designed for "plug and play" connectivity.

+ savings

Maintenance operations are now simpler, faster and more economical:

- > Easy access to the torque limiter.
- > Easy access to safety fuses.
- > New concept of easily dismountable hoisting motor.
- > Easy visual access to the brake for control.



+ improved ergonomics

- > Due to oval shape the chain can't be stock on top of the motor, this reduce the risk of chain jamming. The design with its flowing and refined lines draws attention to its robustness and on-board technology and gives a strong impression of integral safety. The new streamlining provides STAGEMAKER SR and SL better integration in its operating environment (lighting, loudspeakers, etc.).
- > Hoist meets ecology regulations and is RohS compliant.
- > The hoist body is powder coated with black (RAL 7021), protective 70 µm epoxy paint, allowing it to perform under the most extreme conditions (-10 C° to +40 C°).



- > Lifting hook has an ergonomic, rubber clad, gripping surface.
- > New ergonomic concept for the retractable, rubber clad handgrips, allow an easy transportation of the hoist (SL5 and SL10 as standard, SR1 as option).
- > Black CE P17 plug for better integration.

Range

SRI

D8 up to **320** kg
(500 kg on 2 falls)

D8+ up to **250** kg



SLS

D8 up to **500** kg

D8+ up to **500** kg



SL10

D8 up to **1000** kg
(2000 kg on 2 falls)

D8+ up to **1000** kg



SR25

D8 up to **2500** kg
(5000 kg on 2 falls)

D8+ up to **1250** kg
(2500 kg on 2 falls)



Operating configurations

CLIMBING HOIST
CONFIGURATION



INDUSTRIAL
SUSPENSION HOIST
CONFIGURATION



STAGEMAKER

SR1 at a glance

Small but **powerful**
250 kg on one fall (D8+)!
320 kg on one fall (D8)!

D8+
 as standard
 SQP2



Technical characteristics

- > 1 fall (200/250/320 kg) or 2 falls hoist (500 kg).
- > Lifting speed : 4 m/min (1 fall).
- > Center to center hoist.
- > Clutch on the safe side.
- > Same iconic design that actual SR range (oval shape).
- > Hoist body : 100% aluminum body, no plastic parts.
- > Double brake as standard
- > Rotating upper and lower hooks.
- > DIN hooks.
- > Rubber ergonomic grip on top hook.
- > IP55 Protection.
- > 4 x 11 chain.
- > Available in Version A (direct control), Version B (Low voltage control).
- > Black CE P17 plug for better integration.
- > Black lifting chain.
- > Free maintenance brake.
- > RAL7021 epoxy paint.
- > Climbing hoist or industrial suspension configuration can be changed simply by reversing the chain container.
- > **PERFECT PUSH**. New patented concept, 5 pocket load wheel, fitted with 5 intermediate teeth. This innovation provides improved chain guiding and chain flow, to help reduce the risk of chain jamming.
- > **CHAINFLUX** as standard. Horizontal ejection of the chain.
- > Electric limit switch (on B version).

Stagemaker SR1	1 fall		2 falls	
	D8+	D8	D8+	D8
SWL (kg)	Up to 250 kg	Up to 320 kg	Up to 250 kg	Up to 500 kg
Dimensions	Best dimensions on the market with 1 or 2 brakes		Best dimensions on the market with 1 or 2 brakes	
Body weight (kg)	10,4		10,4	
Sound level	50 db		50 db	
Integration into 12" truss	Yes		Yes	
Double brake as standard	Yes		Yes	
Chainflux as standard	Yes		Yes	
PerfectPush as standard	Yes		Yes	
Electric limit switch as standard	Yes <small>(on low voltage type B version)</small>		Yes <small>(on low voltage type B version)</small>	
Versatile use of the hoist <small>(Climbing hoist or industrial suspension)</small>	Yes <small>(just by reversing the hoist)</small>		Yes <small>(just by reversing the hoist)</small>	

Options

- > Version A or B.
- > Handles.



Stagemaker SR1 double brake fits perfectly in a 12" truss.

Types of control and technical characteristics*

Features / Versions

Version A : motor 3 phases with direct control

Version B : motor 3 phases with low voltage control

3 phase hoists (400 V/415 V/3 Ph/50 Hz) with direct voltage control (ACF board)	●	▲
3 phase hoists (400 V/415 V/3 Ph/50 Hz) with low voltage control (48V)	▲	●
BGV-D8+ version	●	●
BGV-D8 version	○	○
Complies with standards : CE, CSA, EAC, EN 17206	●	●
IP 66 (soon available)	▲	▲
Easy changeover for using motor in climbing hoist configuration or industrial suspension	●	●
Hoist delivered with G100 black electro galvanized chain (except SR25)	●	●
"CHAINFlux MKII" specially designed chain guide	●	●
"Limitflux" : magnetic limit switch (SL5 and SL10 1 fall)	▲	●
Electric limit switch on SR1,SL10 (2 falls) and 25	▲	●
Gear limit switches 2 steps	▲	○
Gear limit switches 4 steps	▲	○
"PerfectPush" : new load wheel with 5 pockets and 5 intermediate guide teeth	●	●
Class F hoisting motor	●	●
Adjustable torque limiter	●	●
2 brakes	●	●
1 brake	○	○
Self adjusting, maintenance free, DC disk brake	●	●
Available power supply : 400-415 V/3 Ph/50 Hz	●	●
Available power supply : 400-415 V/3 Ph/60 Hz	○	○
Available power supply : 230 V/3 Ph/50 Hz	○	○
Black painted hoist body (RAL 7021)	●	●
Rotating upper and lower hooks	●	●
Upper hook fixed and lower hook rotating (industrial suspension configuration)	○	○
Suspension bracket instead of upper hook (SL5 & 10)	○	○
Retractable, rubber clad ergonomic handgrips (except SR1 in option and not available on SR25)	●	●
Lifting hook has an ergonomic, rubber clad, gripping surface	●	●
High capacity, reversible chain bag	●	●
Standards connection cable : CE plug P17 type, 4 poles 16A (red : power supply/control)	●	▲
CE plug P17 type, 4 poles 16A (red : power supply and yellow : control)	▲	●

● Standard ○ Option ▲ Not available

Specifications

Load capacity (kg)	D8+ Models (Standard version) 2 brakes	D8 Models (Optional version) 1 brake	Speed 50Hz (m/min)	Number of falls	Chain size (mm)	Motor power (kW)	Weight of hoist: - without chain -with 2 brakes	Weight of chain per meter (kg) ²
125	SR1 124 m	SR1 124 m	4	1	4 x 11	0,2	10,4	0,37
160	SR1 164 m	SR1 164 m	4	1	4 x 11	0,2	10,4	0,37
200	SR1 204 m	SR1 204 m	4	1	4 x 11	0,2	10,4	0,37
250	SR1 254 m	SR1 254 m	4	1	4 x 11	0,2	10,4	0,37
	SR1 252 m	SR1 252 m	2	2 ⁽¹⁾	4 x 11	0,2	10,4	0,37
	SL5 258 m	SL5 258 m	8	1	5,1 x 15,1	0,73	30,8	0,62
	SL5 2516 m	SL5 2516 m	16	1	5,1 x 15,1	0,73	30,8	0,62
320		SR1 324 m	4	1	4 x 11	0,2	10,4	0,37
		SR1 502 m	2	2 ⁽¹⁾	4 x 11	0,2	10,4	0,37
500	SL5 504 m	SL5 504 m	4	1	5,1 x 15,1	0,73	30,8	0,62
		SL5 508 m	8	1	5,1 x 15,1	0,73	30,8	0,62
	SL10 508 m		8	1	7,2 x 21,1	1,8	47,6	1,2
		SL5 516 m	16	1	5,1 x 15,1	0,73	30,8	0,62
800		SL10 516 m	16	1	7,2 x 21,1	1,8	47,6	1,2
	SL10 808 m		4	2	7,2 x 21,1	1,8	47,6	1,2
1000	SL10 1004 m	SL10 1004 m	4	1	7,2 x 21,1	1,8	47,6	1,2
		SL10 1008 m	8	1	7,2 x 21,1	1,8	47,6	1,2
1250	SR25 1204 m	SR25 1204 m	4	1	11,3 x 31	3,6	114,3	2,81
	SR25 1208 m	SR25 1208 m	8	1	11,3 x 31	3,6	114,3	2,81
1600	SL10 1604 m	SL10 1604 m	4	1	11,3 x 31	1,8	47,6	1,2
2000		SL10 2004 m	4	2	7,2 x 21,1	1,8	47,6	1,2
		SR25 2504 m	4	1	11,3 x 31	3,6	114,3	2,81
2500	SR25 2504 m		4	2	11,3 x 31	3,6	114,3	2,81
		SR25 2508 m	8	1	11,3 x 31	3,6	114,3	2,81
5000		SR25 5004 m	4	2	11,3 x 31	3,6	114,3	2,81

(1) Maximum height of lift : 15m

(2) Multiply value by 2 for 2 falls unit

