

## SPARE PARTS VR02 – PHASE 2

To avoid errors when ordering please specify:

- Complete type of hoist
- Date of manufacture and serial number
- Spare part code
- Spare part designation
- Additional information



## **1) FRAME**

- 1.1) Upper hook
- 1.2) Manual trolley
- 1.3) Electric trolley

## **2) CHAIN GUIDE - CHAIN 4X11**

- 2.1) Automatic hook - 1 fall
- 2.2) Standard & Stainless steel hook - 1 fall
- 2.3) Standard & Stainless steel hook - 2 falls
- 2.4) RSN standard hook - Digichain
- 2.5) Automatic hook - Digichain
- 2.6) Pre-cut chain

## **3) GEAR - STANDARD**

- 3.1) Single & double brakes - Higher than 63 kg
- 3.2) Single & double brakes - Lower or equal to 63 kg

## **4) GEAR - LIMIT SWITCH**

- 4.1) Single & double brakes - Higher than 63 kg
- 4.2) Single & double brakes - Lower or equal to 63 kg

## **5) MOTOR**

- 5.1) Single brake
- 5.2) Double brakes

## **6) ELECTRICAL PARTS**

- 6.1) Solo equipment - Standard
- 6.2) Equipment for Eurosystem steel & Alu.& PRV
- 6.3) Equipment for crane kit - For UT+GTR+GTN
- 6.4) Without electric component
- 6.5) Direct voltage - ACF
- 6.6) Solo hoist - Hard wiring

## **7) PUSH BUTTON CONTROLLER**

- 7.1) 2 buttons
- 7.2) 4 buttons
- 7.3) 6 buttons
- 7.4) Push button controller - From September 2014

## **8) NORMAL HEADROOM TROLLEY**

- 8.1) C1 trolley - 0 to 1000 kg - Coupled version
- 8.2) Inverter TMU motor for VR hoist
- 8.3) Two speeds TMU motor for VR hoist
- 8.4) Chain travel
- 8.5) Right angle motor

## **9) LOW HEADROOM TROLLEY**

- 9.1) LHT - 1 fall
- 9.2) LHT - 2 falls

## **10) MANUAL TROLLEY CHD**

# 1) FRAME

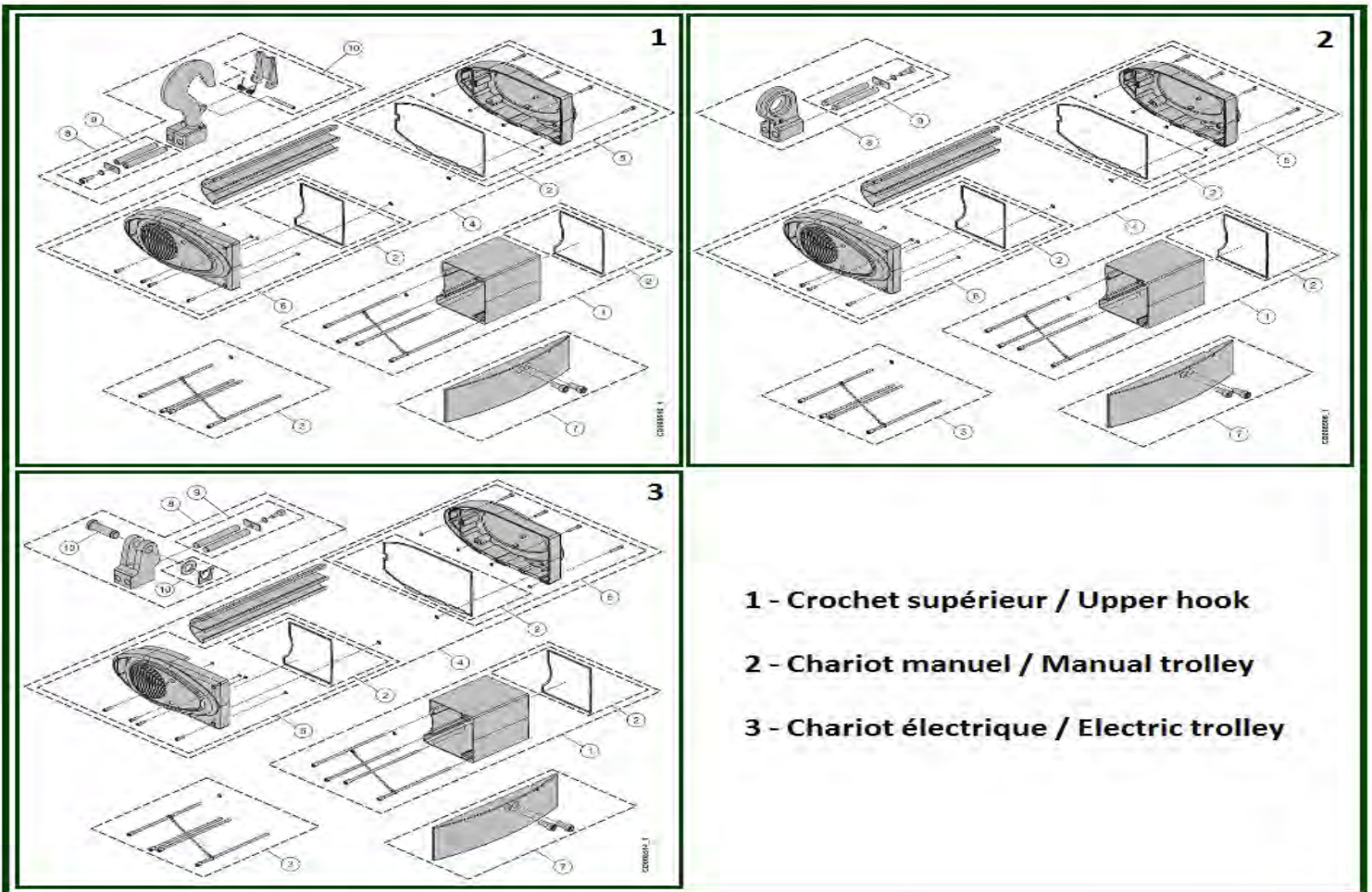

## 1.1) UPPER HOOK

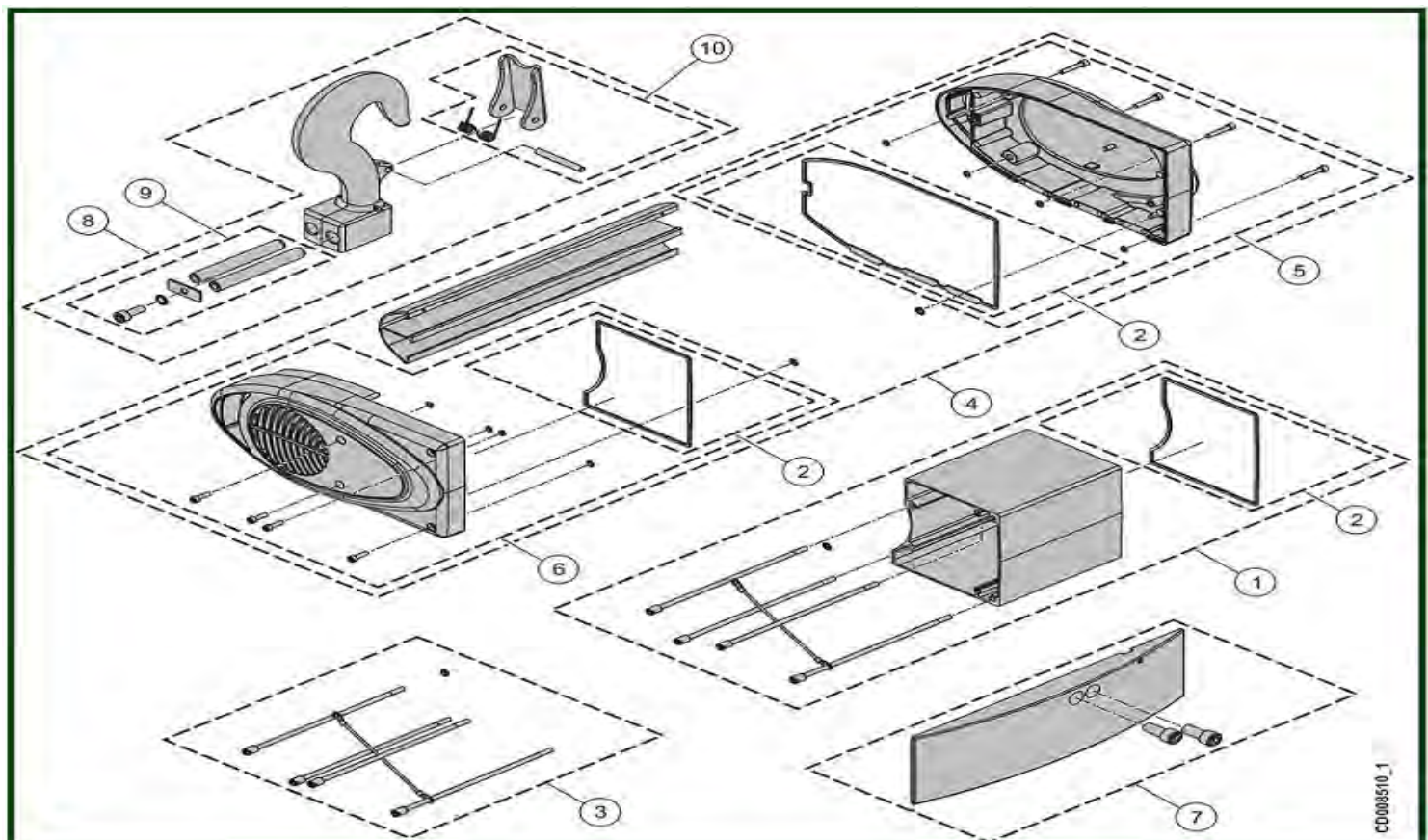



ITEM	REFERENCE	DESCRIPTION
1	VT0009069	Housing module, Standard
2	VT0009309	Sealings set
3	VT0006279	Screw set M6L155 - Motor side, single brake
4	VT0009084	Cover standard
5	VT0009086	Cover set - Brake side, Standard
6	VT0009087	Cover set - Motor side, Standard
7	VT0009070	Counterweight
8	VT0009088	Upper hook
9	VT0009091	Shaft set
10	VT0004927	Safety latch set, Standard hook (VT0005901)
-	VT0006026	Identification plate, Serial number request
-	VT0009096	Rain cover, Standard
-	VT0006451	Set of 10 load plates – Hoist, 63 Kg
-	VT0006241	Set of 10 load plates – Hoist, 125 Kg
-	VT0006450	Set of 10 load plates – Hoist, 160 Kg
-	VT0006091	Set of 10 load plates – Hoist, 250 Kg
-	VT0006449	Set of 10 load plates – Hoist, 320 Kg

## 1.2) MANUAL TROLLEY

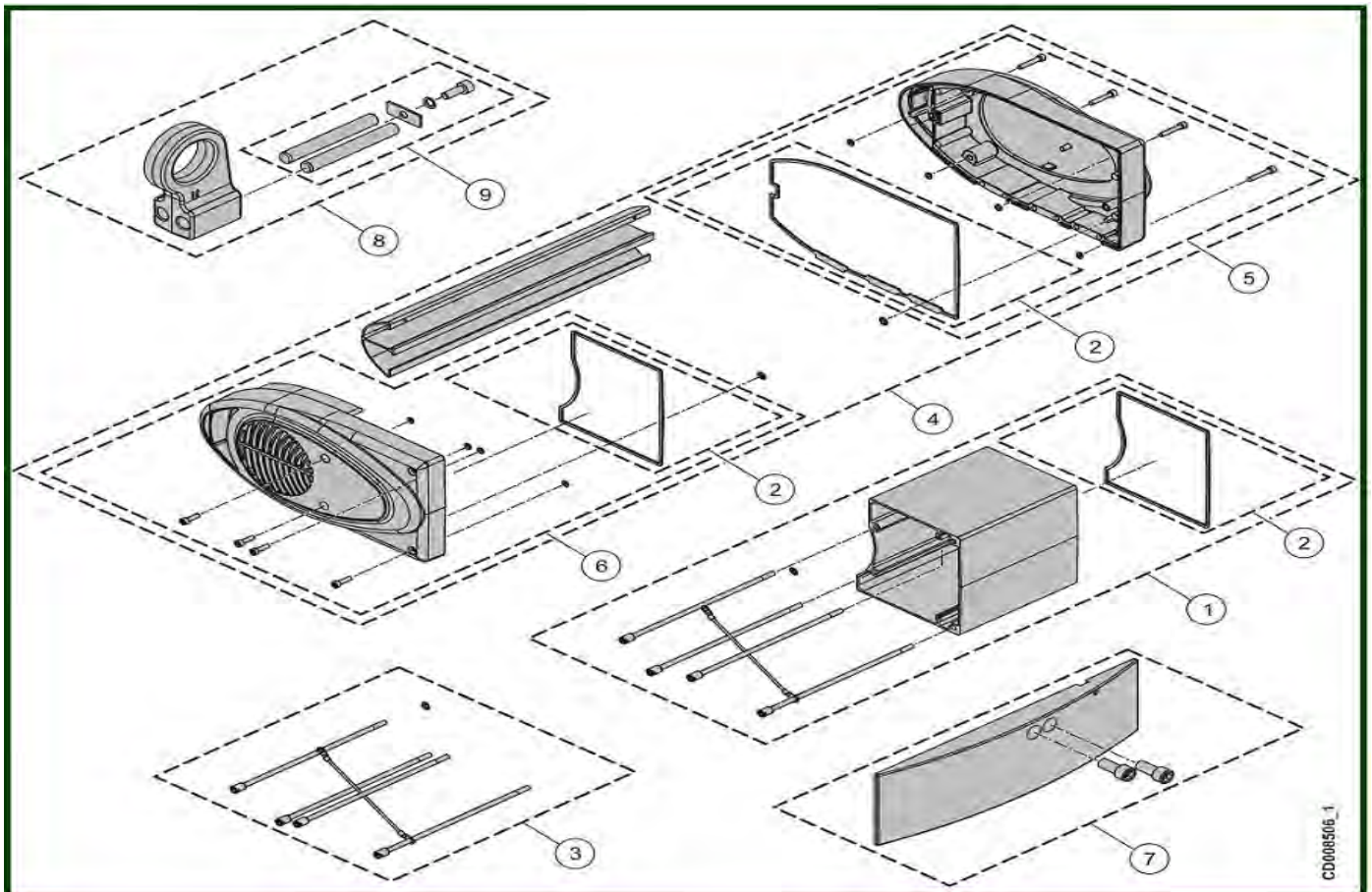

ITEM	REFERENCE	DESCRIPTION
1	VT0009069	Housing module, Standard
2	VT0009309	Sealings set
3	VT0006279	Screw set M6L155 - Motor side, single brake
4	VT0009084	Cover standard
5	VT0009086	Cover set - Brake side, Standard
6	VT0009087	Cover set - Motor side, Standard
7	VT0009070	Counterweight
8	VT0009089	Coupling part - Manual trolley
9	VT0009091	Shaft set
-	VT0006026	Identification plate, Serial number request
-	VT0006451	Set of 10 load plates – Hoist, 63 Kg
-	VT0006241	Set of 10 load plates – Hoist, 125 Kg
-	VT0006450	Set of 10 load plates – Hoist, 160 Kg
-	VT0006091	Set of 10 load plates – Hoist, 250 Kg
-	VT0006449	Set of 10 load plates – Hoist, 320 Kg
-	VT0009096	Rain cover, Standard

### **1.3) ELECTRIC TROLLEY**

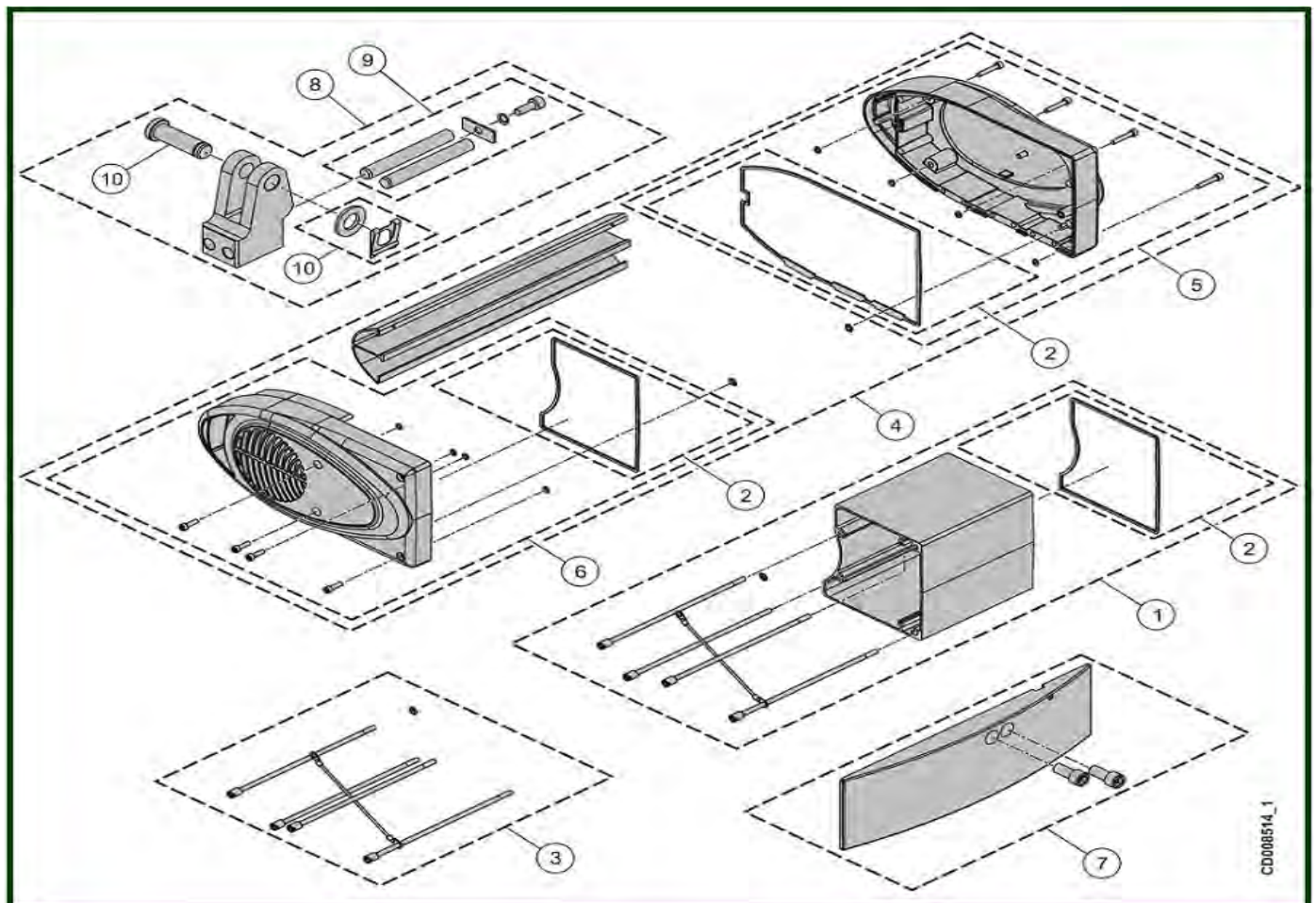

ITEM	REFERENCE	DESCRIPTION
1	VT0009069	Housing module, Standard
2	VT0009309	Seal set
3	VT0006279	Screw set M6L155 - Motor side, single brake
4	VT0009084	Cover standard
5	VT0009086	Cover set - Brake side, Standard
6	VT0009087	Cover set - Motor side, Standard
7	VT0009070	Counterweight
8	VT0009090	Coupling part, Electric trolley
9	VT0009091	Shaft set
10	VT0009407	Shaft set, Electric trolley
-	VT0006026	Identification plate, Serial number request
-	VT0006451	Set of 10 load plates – Hoist, 63 Kg
-	VT0006241	Set of 10 load plates – Hoist, 125 Kg
-	VT0006450	Set of 10 load plates – Hoist, 160 Kg
-	VT0006091	Set of 10 load plates – Hoist, 250 Kg
-	VT0006449	Set of 10 load plates – Hoist, 320 Kg
-	VT0009096	Rain cover, Standard



## 2) CHAIN GUIDE - CHAIN 4x11

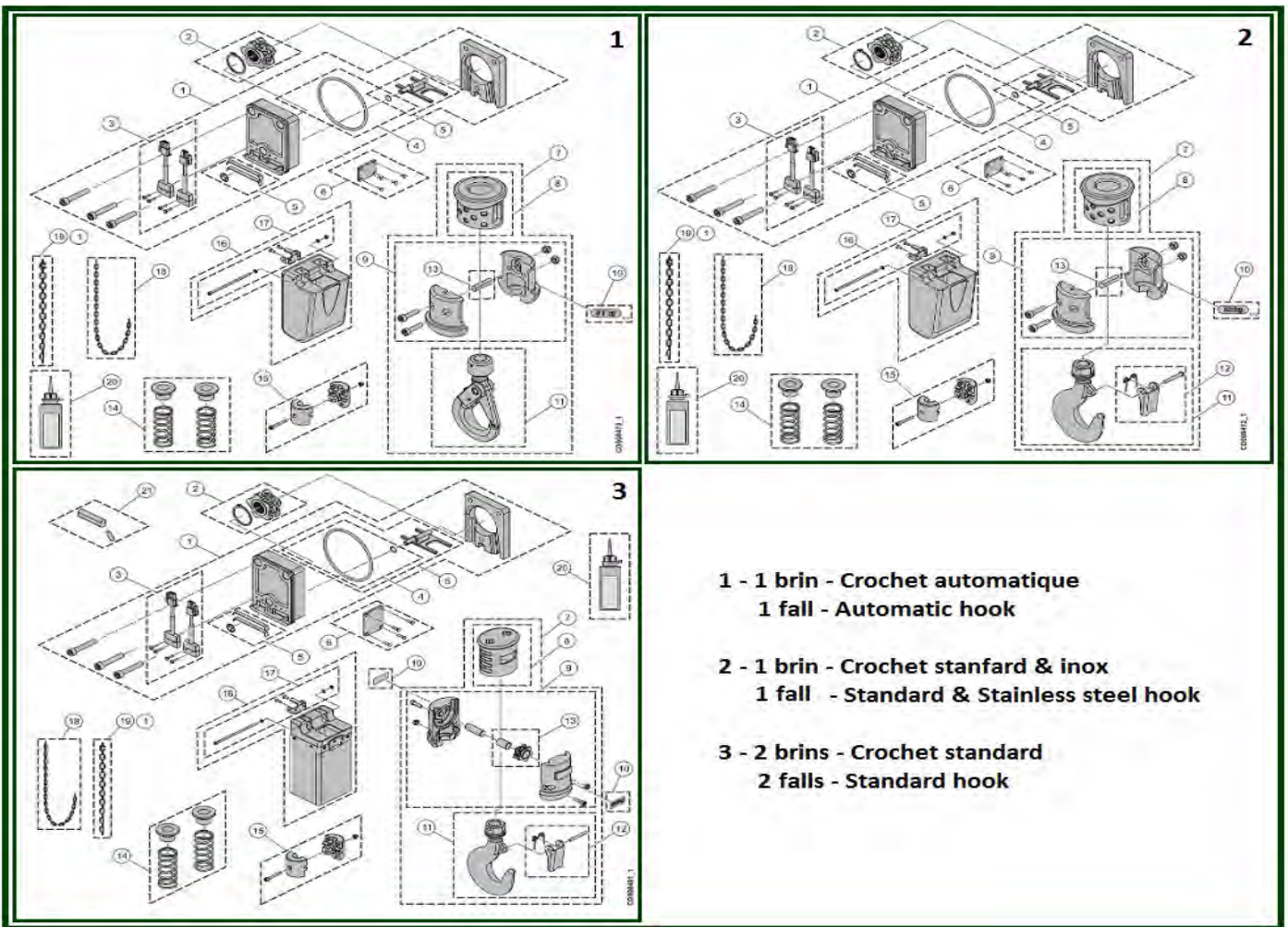

### 2.1) AUTOMATIC HOOK - 1 FALL

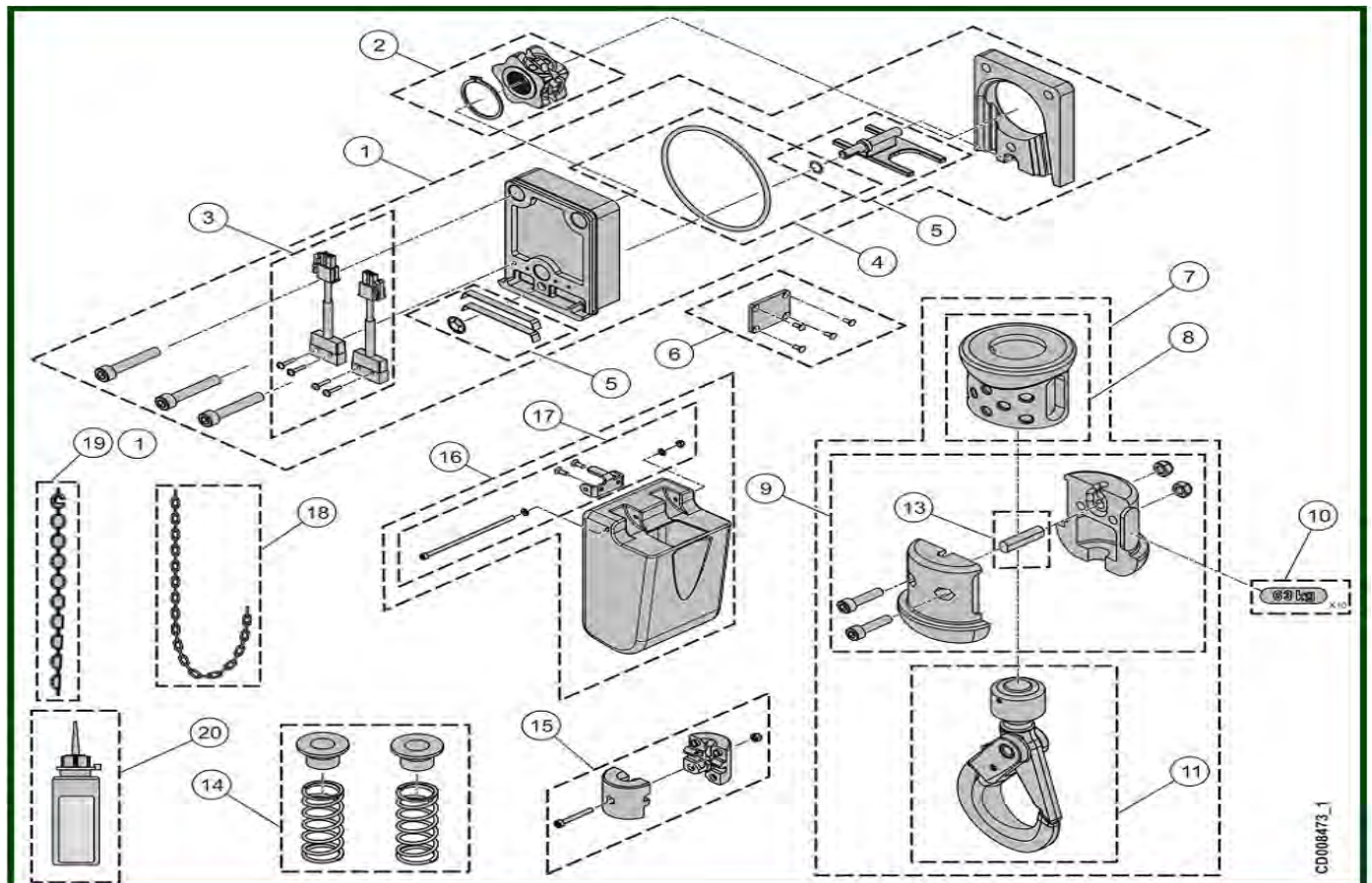

ITEM	REFERENCE	DESCRIPTION
1	VT0006426	Chain guide, Chain 4x11
2	VT0004540	Chain sprocket
3	VT0004724	Switch set
4	VT0005096	Seal set
5	VT0004541	Limit switch activator
6	VT0005087	End cap, Chain guide
7	VT0009131	Hook block, Automatic
8	VT0007183	Rubber sleeve, 1 fall
9	VT0004725	Half casing set
10	VT0006285	Set of 10 load plates – Hoist, 63 kg
10	VT0006344	Set of 10 load plates – Hoist, 125 kg
10	VT0006345	Set of 10 load plates – Hoist, 160 kg
10	VT0006346	Set of 10 load plates – Hoist, 250 kg
10	VT0006347	Set of 10 load plates – Hoist, 320 kg
11	VT0006427	Lower hook assembly, Automatic 1+2 falls
13	VT0006093	Pin
14	VT0009186	Spring set (/slack fall stop)
15	VT0007215	Chain stop
16	VT0009105	Chain bucket, 6 m for 4x11
16	VT0009106	Chain bucket, 16 m for 4x11
16	VT0009107	Chain bucket, 35 m for 4x11
17	VT0009108	Fixing set of chain bucket, D6L151
18	VT0005076	Galvanized chain - 4x11, Standard
18	VT0006274	Stainless steel chain - 4x11, Beware, hoist downgraded
19	VT0005573	Chain fitting tool, CHCM-011
20	VT0006025	Oil can



## 2.2) STANDARD & STAINLESS - STEEL HOOK - 1 FALL

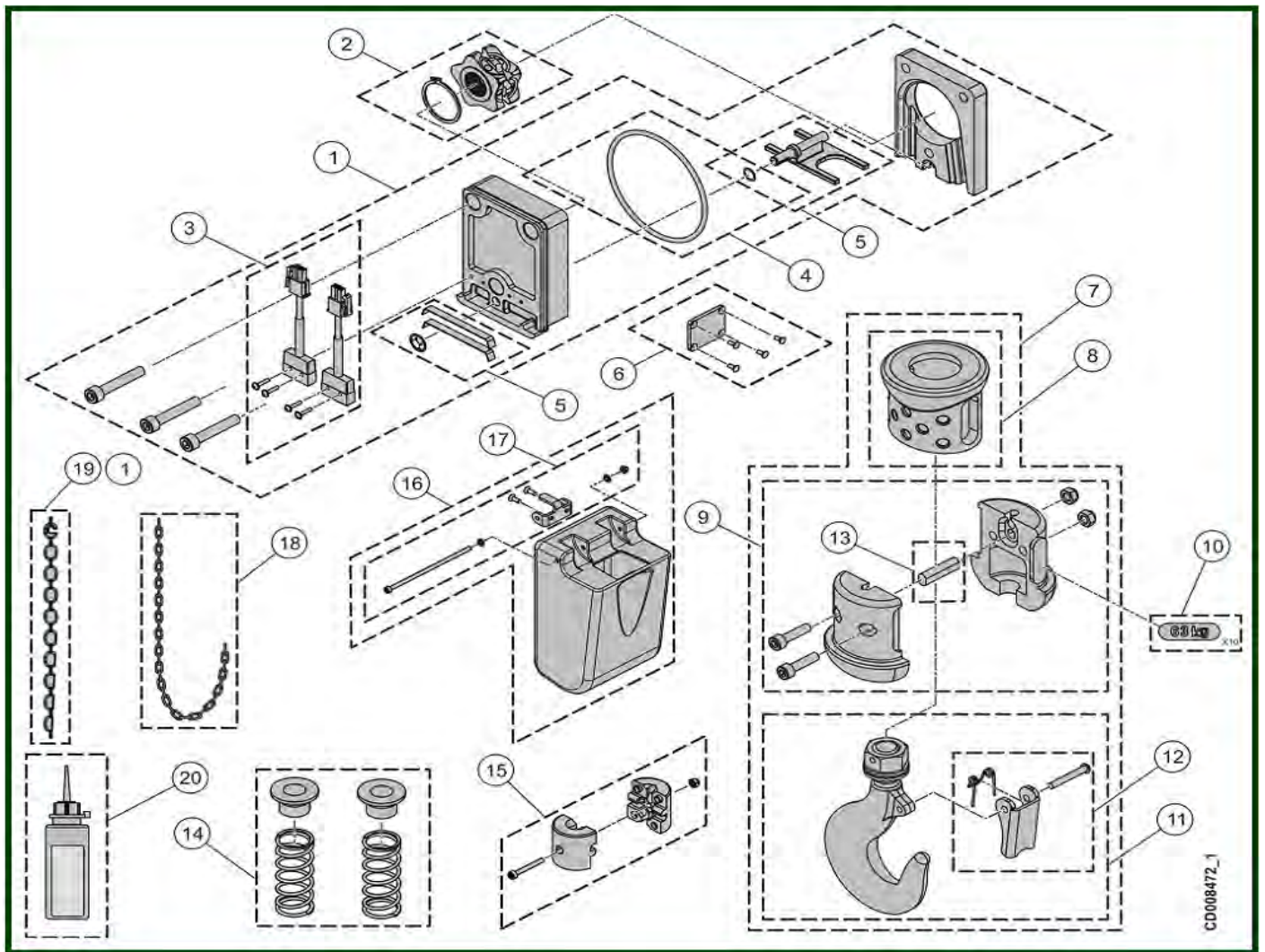

ITEM	REFERENCE	DESCRIPTION
1	VT0006426	Chain guide, Chain 4x11
2	VT0004540	Chain sprocket
3	VT0004724	Switch set
4	VT0005096	Seal set
5	VT0004541	Limit switch activator
6	VT0005087	End cap, Chain guide
7	VT0009130	Hook block, Stainless steel hook
7	VT0009129	Hook block, Standard
8	VT0007183	Rubber sleeve, 1 fall
9	VT0007290	Half-casing set, Inox
10	VT0006285	Set of 10 load plates – Hoist, 63 kg
10	VT0006344	Set of 10 load plates – Hoist, 125 kg
10	VT0006345	Set of 10 load plates – Hoist, 160 kg

10	VT0006346	Set of 10 load plates – Hoist, 250 kg
10	VT0006347	Set of 10 load plates – Hoist, 320 kg
11	VT0006455	Hook assembly, Beware: Stainless steel chain - Max load has to be decreased
11	VT0004926	Hook assembly, Standard
12	VT0007304	Safety latch set, Crochet inox / Stainless steel hook
12	VT0004905	Safety latch set, Standard
13	VT0006093	Pin
14	VT0009186	Spring set (/slack fall stop)
15	VT0007215	Chain stop
16	VT0009105	Chain bucket, 6 m for 4x11
16	VT0009106	Chain bucket, 16 m for 4x11
16	VT0009107	Chain bucket, 35 m for 4x11
17	VT0009108	Fixing set of chain bucket, D6L151
18	VT0005076	Galvanized chain - 4x11, Standard
18	VT0006274	Stainless steel chain - 4x11, Beware: hoist downgraded
19	VT0005573	Chain fitting tool, CHCM-011
20	VT0006025	Oil can

### **2.3) STANDARD & STAINLESS-STEEL HOOK - 2 FALLS**

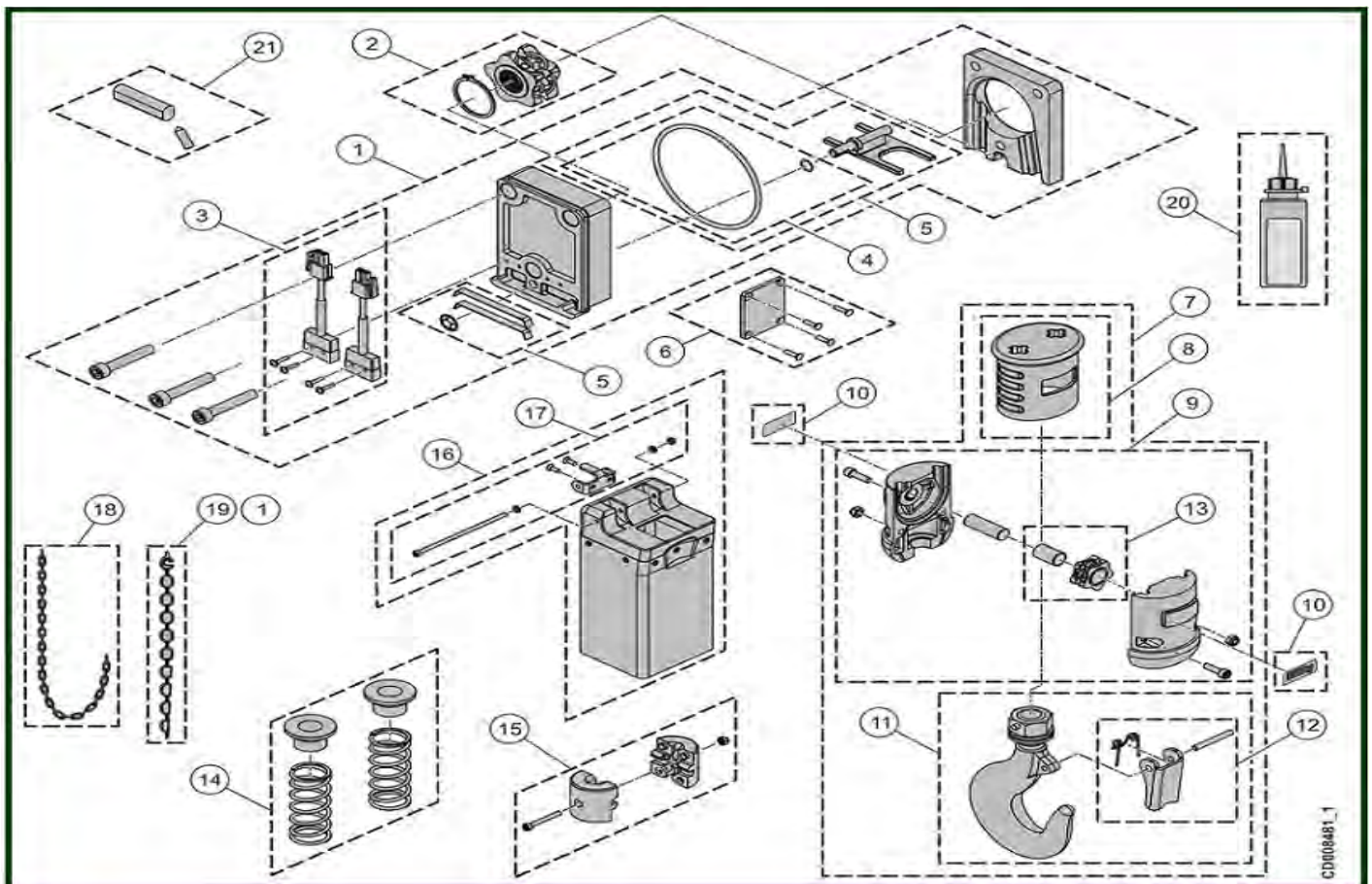

ITEM	REFERENCE	DESCRIPTION
1	VT0006426	Chain guide, Chain 4x11
2	VT0004540	Chain sprocket
3	VT0004724	Switch set
4	VT0006096	Seal
5	VT0004541	Limit switch activator
6	VT0005087	End cap, Chain guide
7	VT0009101	Hook block - 2 falls, Standard hook + Standard hook block
8	VT0007191	Rubber sleeve, 2 falls
9	VT0009324	Hook component, Standard hook + safety hook
10	VT0009111	Set of 10 load plates, 500 Kg
11	VT0006452	Stainless steel hook
11	VT0004975	Standard hook
12	VT0005901	Standard safety latch
13	VT0007220	Return sprocket, 2 falls
14	VT0009186	Spring set (/slack fall stop)
15	VT0007215	Chain stop
16	VT0009105	Chain bucket, 6 m for 4x11
16	VT0009106	Chain bucket, 16 m for 4x11
16	VT0009107	Chain bucket, 35 m for 4x11
17	VT0009108	Fixing set of chain bucket, D6L151
18	VT0005076	Galvanized chain - 4x11, Standard
18	VT0006274	Stainless steel chain - 4x11, Beware hoist downgraded
19	VT0005573	Chain fitting tool, CHCM-011
20	VT0006025	Oil can
21	VT0009104	Fixing module



## 2.4) RSN STANDARD HOOK - DIGICHAIN

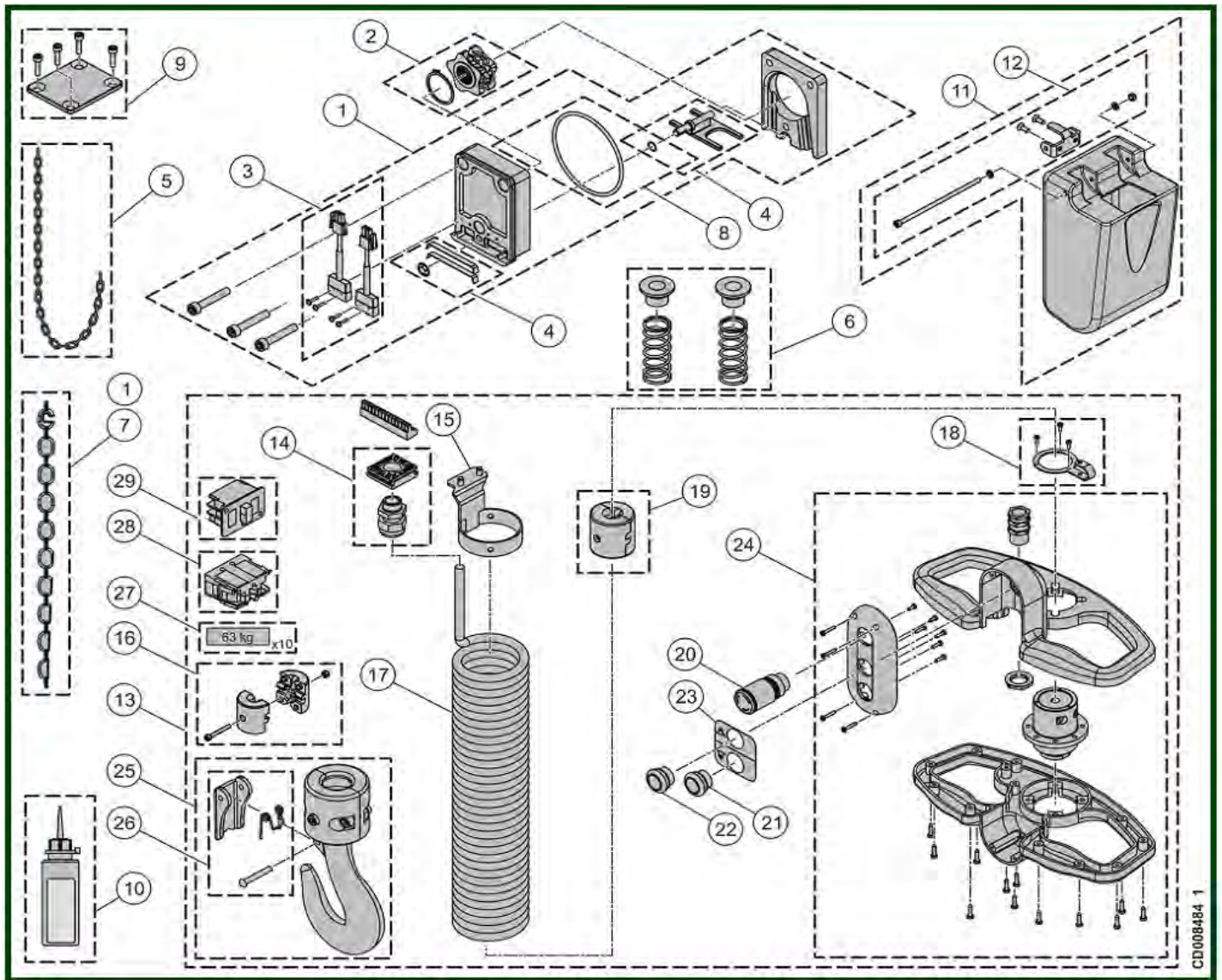

ITEM	REFERENCE	DESCRIPTION
1	VT0006426	Chain guide, Chain 4x11
2	VT0004540	Chain sprocket
3	VT0004724	Switch set
4	VT0004541	Limit switch activator
5	VT0005076	Galvanized chain - 4x11, Standard
5	VT0006274	Stainless steel chain - 4x11, Beware: hoist downgraded
6	VT0009186	Spring set (/slack fall stop)
7	VT0005573	Chain fitting tool, CHCM-011
8	VT0006096	Sealing
9	VT0005087	End cap, Chain guide
10	VT0006025	Oil can



11	VT0009105	Chain bucket, 6 m for 4x11
11	VT0009106	Chain bucket, 16 m for 4x11
11	VT0009107	Chain bucket, 35 m for 4x11
12	VT0009108	Fixing set of chain bucket, D6L151
13	VT0009223	Complete hook block, 3m - Standard hook
13	VT0009222	Complete hook block, 5m - Standard hook
14	VT0006393	Cable gland set - Square cable entry, CG M20- ISO 20 -Power supply
15	VT0009226	Fixing set, W32H148T3
16	VT0007215	Chain stop
17	VT0009205	Spiral cable, Lg 3m
17	VT0009206	Spiral cable, Lg 5m
18	VT0008839	Fixing plate
19	VT0009207	Coupling set, D35H45
20	VT0006548	Emergency push button
21	VT0009208	White button, XACA9411
22	VT0009209	Push button, XACA9412
23	VT0009210	Up & down sticker, CCGCPBPB-00
24	VT0009211	Pendant box module, CC05PBPB-01
25	VT0009014	Standard safety hook, RSN020T-HCH
26	VT0004968	Safety latch set, Single brake - Standard hook 0,12T-0,25T
27	VT0009164	Set of 10 load plates, 63 kg
27	VT0009165	Set of 10 load plates, 80 kg
27	VT0009166	Set of 10 load plates, 125 kg
27	VT0009167	Set of 10 load plates, 160 kg
27	VT0009168	Set of 10 load plates, 250 kg
27	VT0009169	Set of 10 load plates, 320 kg
27	VT0009170	Set of 10 load plates, 500 kg
28	VT0009212	Contact block, XAC-S 414
29	VT0007879	Contact block, XENG1191

## 2.5) AUTOMATIC HOOK - DIGICHAIN

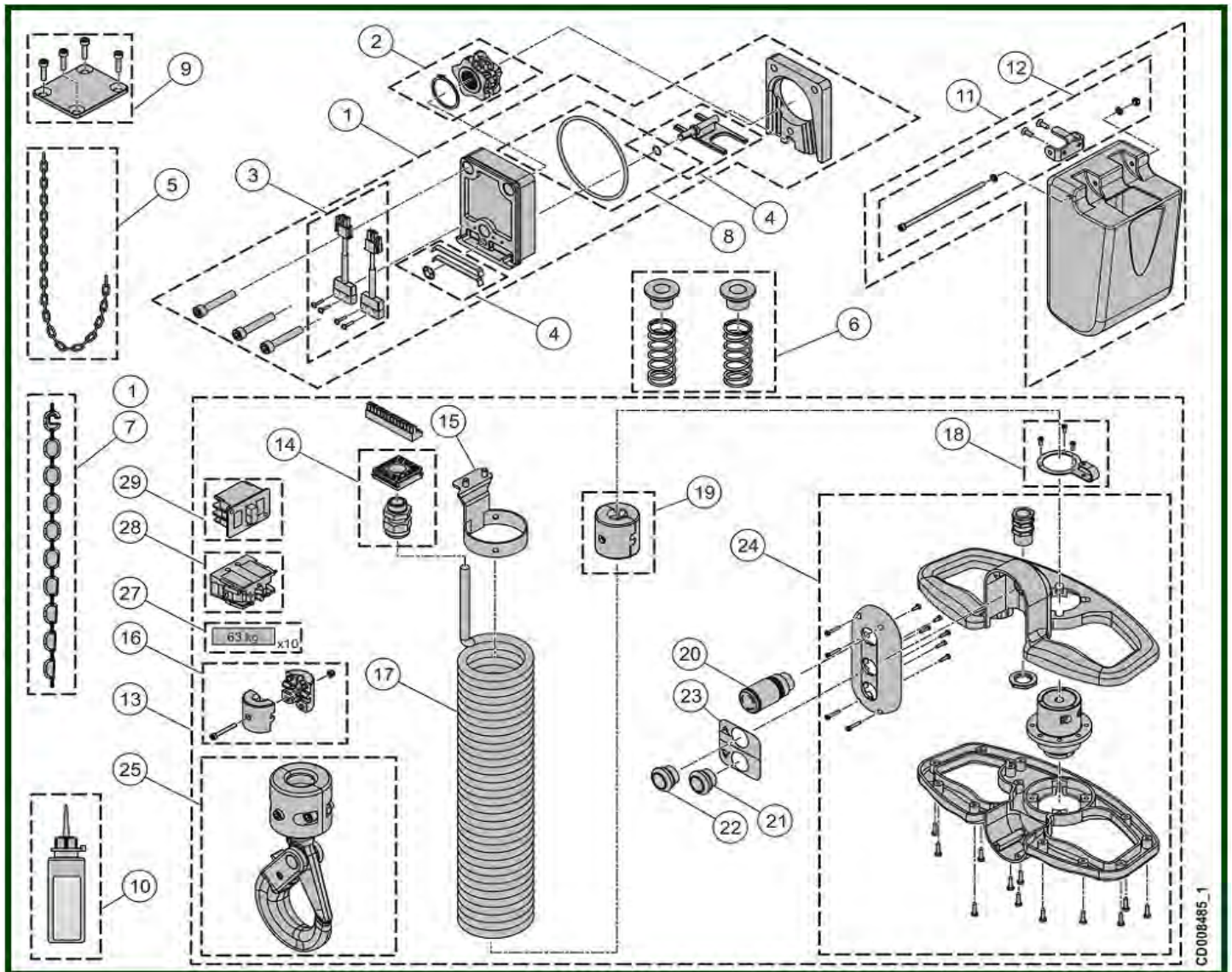

ITEM	REFERENCE	DESCRIPTION
1	VT0006426	Chain guide, Chain 4x11
2	VT0004540	Chain sprocket
3	VT0004724	Switch set
4	VT0004541	Limit switch activator
5	VT0005076	Galvanized chain - 4x11, Standard
5	VT0006274	Stainless steel chain - 4x11, Attention: Be careful, hoist downgraded
6	VT0009186	Spring set (/slack fall stop)
7	VT0005573	Chain fitting tool, CHCM-011
8	VT0006096	Seal
9	VT0005087	End cap, Chain guide
10	VT0006025	Oil can
11	VT0009105	Chain bucket, 6 m for 4x11

11	VT0009106	Chain bucket, 16 m for 4x11
11	VT0009107	Chain bucket, 35 m for 4x11
12	VT0009108	Fixing set of chain bucket, D6L151
13	VT0009224	Complete hook block, 3m - Automatic hook
13	VT0009225	Complete hook block, 5m - Automatic hook
14	VT0006393	Cable gland set - Square cable entry, CG M20- ISO 20 Trolley-Power supply
15	VT0009226	Fixing set, W32H148T3
16	VT0007215	Chain stop
17	VT0009205	Spiral cable, Lg 3m
17	VT0009206	Spiral cable, Lg 5m
18	VT0008839	Fixing plate
19	VT0009207	Coupling set, D35H45
20	VT0006548	Emergency push button
21	VT0009208	White button, XACA9411
22	VT0009209	Push button, XACA9412
23	VT0009210	Up & down sticker, CCGCPBPB-00
24	VT0009211	Pendant box module, CC05PBPB-01
25	VT0009227	Safety hook, HCH - Automatic
27	VT0009164	Set of 10 load plates, 63 kg
27	VT0009165	Set of 10 load plates, 80 kg
27	VT0009166	Set of 10 load plates, 125 kg
27	VT0009167	Set of 10 load plates, 160 kg
27	VT0009168	Set of 10 load plates, 250 kg
27	VT0009169	Set of 10 load plates, 320 kg
27	VT0009170	Set of 10 load plates, 500 kg
28	VT0009212	Contact block, XAC-S 414
29	VT0007879	Contact block, XENG1191

## **2.6) PRE-CUT CHAIN**

<b>ITEM</b>	<b>REFERENCE</b>	<b>DESCRIPTION</b>
-	53020235	Galvanized load chain, 4x11, 4 m
-	53020251	Galvanized load chain, 4x11, 6 m

### 3) GEAR - STANDARD

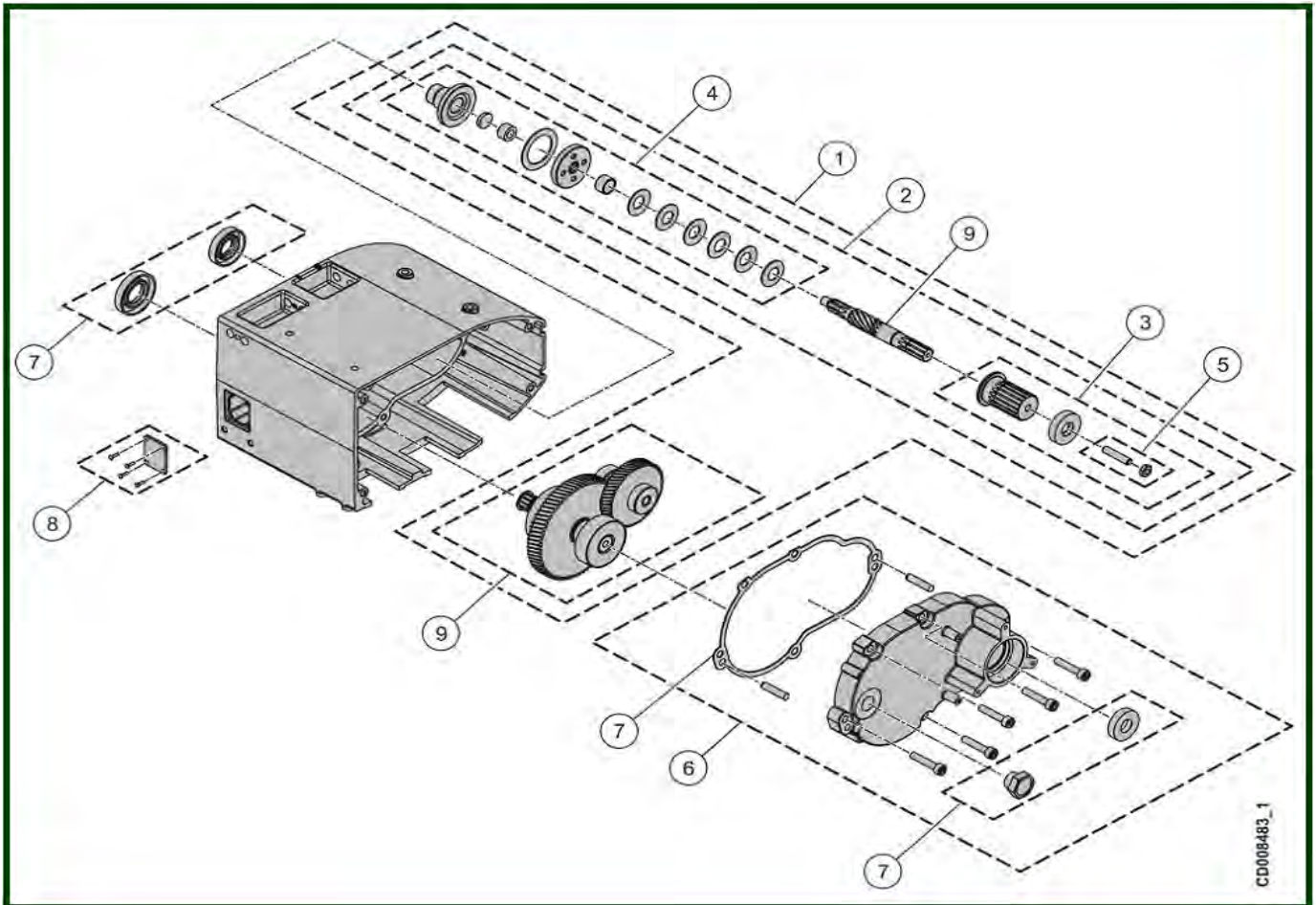

#### 3.1) SINGLE & DOUBLE BRAKES - HIGHER THAN 63 KG

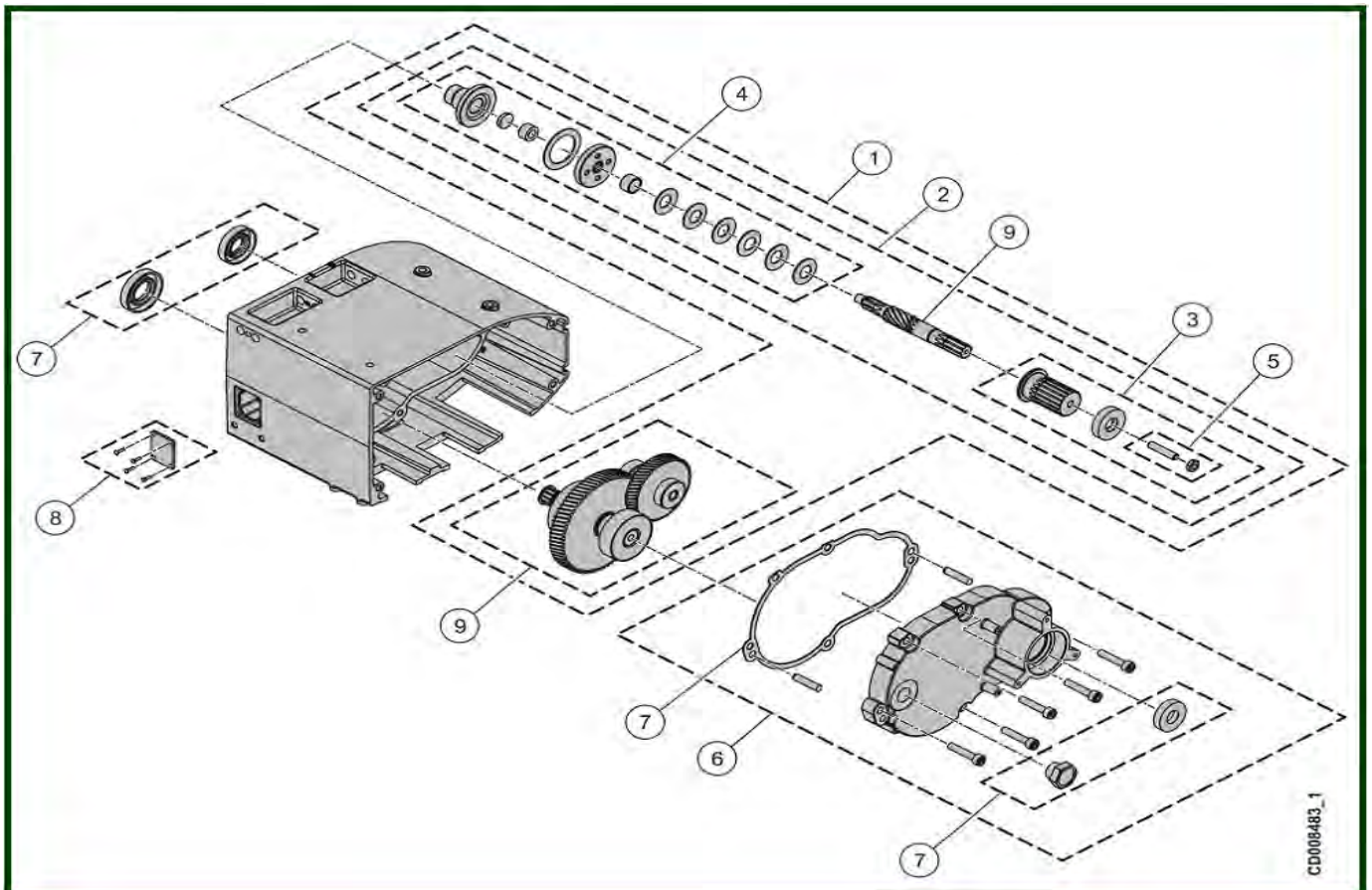



ITEM	REFERENCE	DESCRIPTION
1	VT0007642	Gear / Pinion set, 4/8m/min, Double brake
1	VT0006286	Gear / Pinion set, 4/8m/min, Single brake
1	VT0007643	Gear / Pinion set ,10m/min, Double brake
1	VT0006289	Gear / Pinion set, 10m/min, Single brake
1	VT0007644	Gear / Pinion set, 16m/min, Double brake
1	VT0006290	Gear / Pinion set, 16m/min, Single brake
2	VT0007650	Gear shaft with clutch, Double brake
2	VT0004727	Gear shaft with clutch, Single brake
3	VT0004548	Coupling - Brake side, Single brake
3	VT0007641	Coupling - Side brake, Double brake
4	VT0004939	Clutch, Superior to 63 kg
5	VT0006107	Screw set
6	VT0009103	Gear housing set
7	VT0009099	Seal set
8	VT0005087	End cap, Chain guide
9	VT0004935	Gear assembly, 4/8m/min, Single brake
9	VT0004938	Gear assembly, 10m/min
9	VT0004936	Gear assembly, 16m/min

### **3.2) SINGLE & DOUBLE BRAKES - LOWER OR EQUAL TO 63 KG**

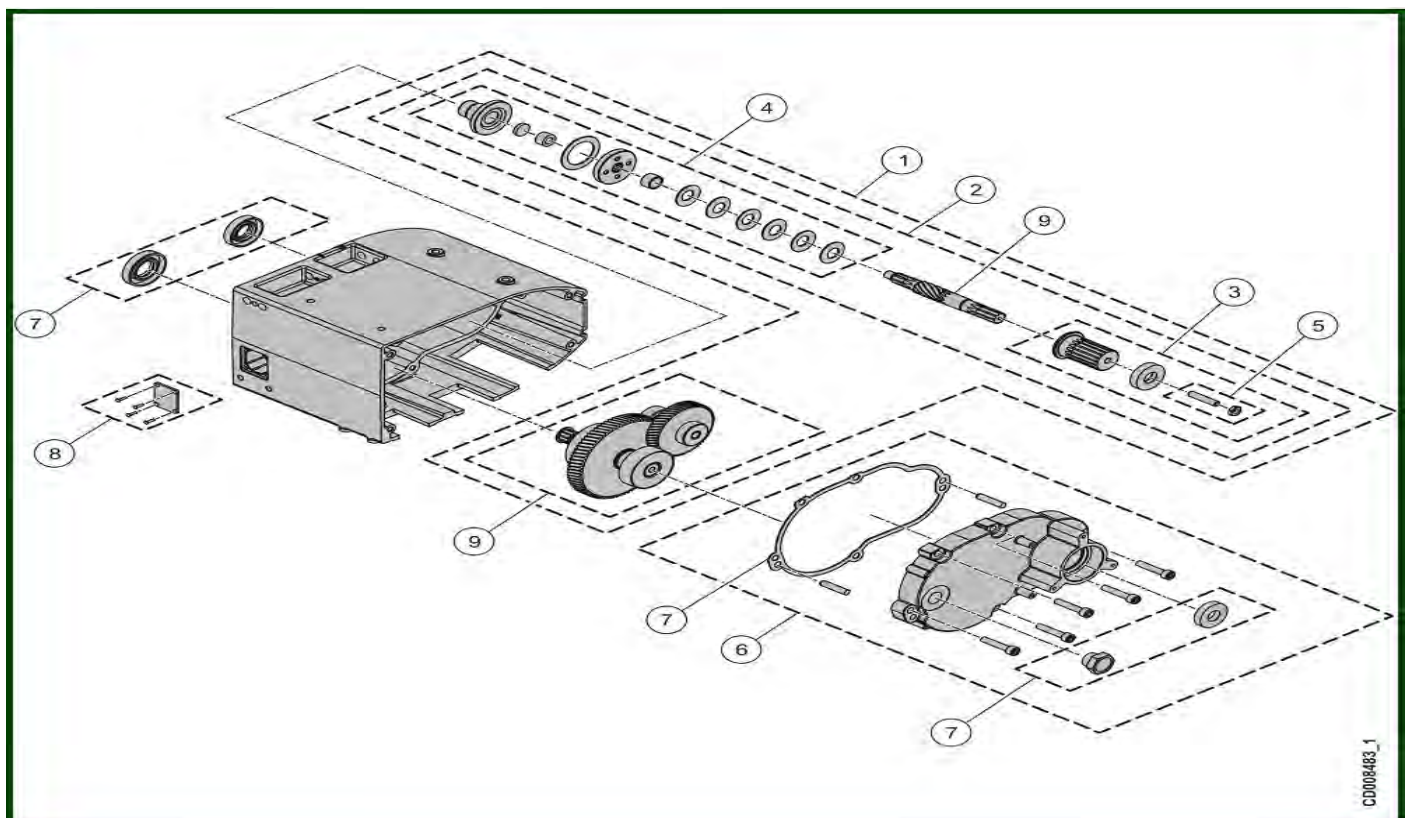

ITEM	REFERENCE	DESCRIPTION
1	VT0007634	Gear - Pinion set, Inferior or equal to 63 kg, 4m/8m/min
1	VT0007635	Gear - Pinion set, Inferior or equal to 63 kg, 10m/min
1	VT0007638	Gear - Pinion set, Inferior or equal to 63 kg, 16m/min
1	VT0007639	Gear - Pinion set, Inferior or equal to 63 kg, 20m/min
1	VT0007646	Gear - Pinion set, Inferior or equal to 63 Kg, 4m/8m/min
1	VT0007647	Gear - Pinion set, Inferior or equal to 63 Kg, 10m/min
1	VT0007648	Gear - Pinion set, Inferior or equal to 63 Kg, 16m/min
1	VT0007649	Gear - Pinion set, Inferior or equal to 63 Kg, 20m/min
2	VT0007651	Gear shaft with clutch, Inferior or equal to 63 Kg, Double brakes
2	VT0007640	Gear shaft with clutch, Inferior or equal to 63 Kg, Single brake
3	VT0007641	Coupling - Side brake, Double brakes
3	VT0004727	Gear shaft with clutch, Single brake
4	VT0006114	Clutch, Inferior or equal to 63 kg
5	VT0006107	Screws set
6	VT0009103	Gear housing set
7	VT0009099	Sealing set
8	VT0005087	End cap, Chain guide
9	VT0004937	Gear assembly, 20m/min
9	VT0004935	Gear assembly, 4/8m/min, Single brake
9	VT0004938	Gear assembly, 10m/min
9	VT0004936	Gear assembly, 16m/min

#### **4) GEAR - LIMIT SWITCH**

#### 4.1) SINGLE & DOUBLE BRAKES - HIGHER THAN 63 KG

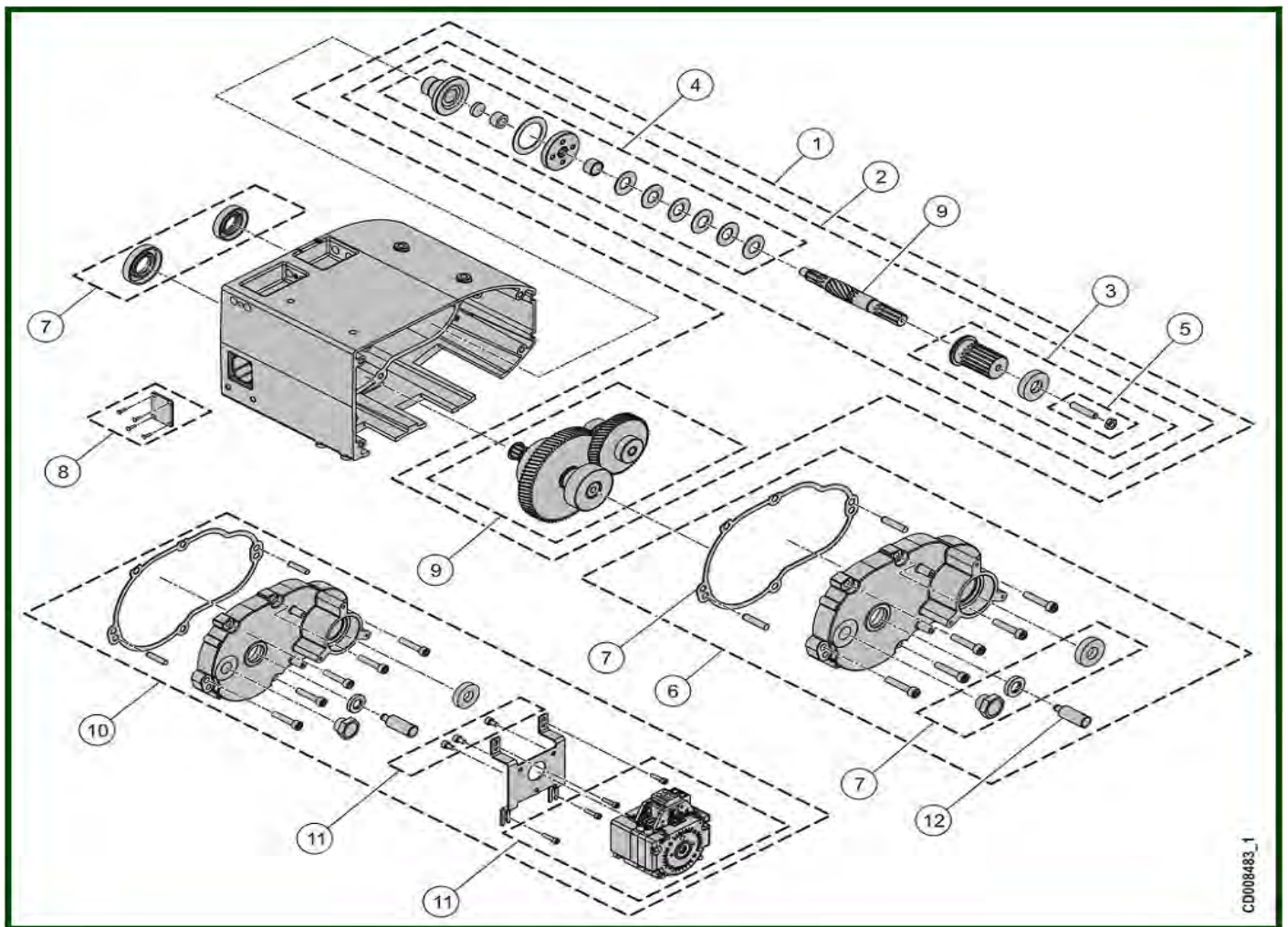

CD0008483\_1

ITEM	REFERENCE	DESCRIPTION
1	VT0007642	Gear - Pinion set, 4/8m/min, Double brake
1	VT0006286	Gear - Pinion set, 4/8m/min, Single brake
1	VT0007643	Gear - Pinion set, 10m/min, Double brake
1	VT0006289	Gear - Pinion set, 10m/min, Single brake
1	VT0007644	Gear - Pinion set, 16m/min, Double brake
1	VT0006290	Gear - Pinion set, 16m/min, Single brake
2	VT0007650	Gear shaft with clutch, Double brake
3	VT0007641	Coupling - Side brake, Double brake
3	VT0004727	Gear shaft with clutch, Single brake
4	VT0004939	Clutch, Superior to 63 kg
5	VT0006107	Screw set
6	VT0009112	Gear housing set
7	VT0009113	Seal set
8	VT0005087	End cap, Chain guide

9	VT0004935	Gear assembly, 4/8m/min, Single brake
9	VT0004938	Gear assembly, 10m/min
9	VT0004936	Gear assembly, 16m/min
10	VT0009127	Adaptation set of geared limit switch, 2 steps, VR02F=20m: 1 fall-10m: 2 falls, VR05F=25m: 1 fall-12.5m: 2 falls, VR10F=36m: 1 fall-18m: 2 falls, VR16F=48m: 1 fall-24m: 2 falls, VR25F=56m: 1 fall-28m: 2 falls
10	VT0009128	Adaptation set of geared limit switch, 4 steps, VR02F=20m: 1 fall-10m: 2 falls, VR05F=25m: 1 fall-12.5m: 2 falls, VR10F=36m: 1 fall-18m: 2 falls, VR16F=48m: 1 fall-24m: 2 falls, VR25F=56m: 1 fall-28m: 2 falls
11	VT0006113	Rotating limit switch - 2 steps, VR02=>20m: 1 fall, VR05=>25m: 1 fall VR12=>36m: 1 fall - 18m: 2 falls, VR16=>48m: 1 fall - 24m: 2 falls, VR25=>56m: 1 fall - 28m: 2 falls
11	VT0006252	Rotating limit switch - 4 steps, VR02=>20m: 1 fall, VR05=>25m: 1 fall, VR12=>36m: 1 fall - 18m: 2 falls, VR16=>48m: 1 fall - 24m: 2 falls, VR25=>56m: 1 fall - 28m: 2 falls
12	VT0009109	Shaft, For geared limit switch

#### 4.2) SINGLE & DOUBLE BRAKES - LOWER OR EQUAL TO 63 KG

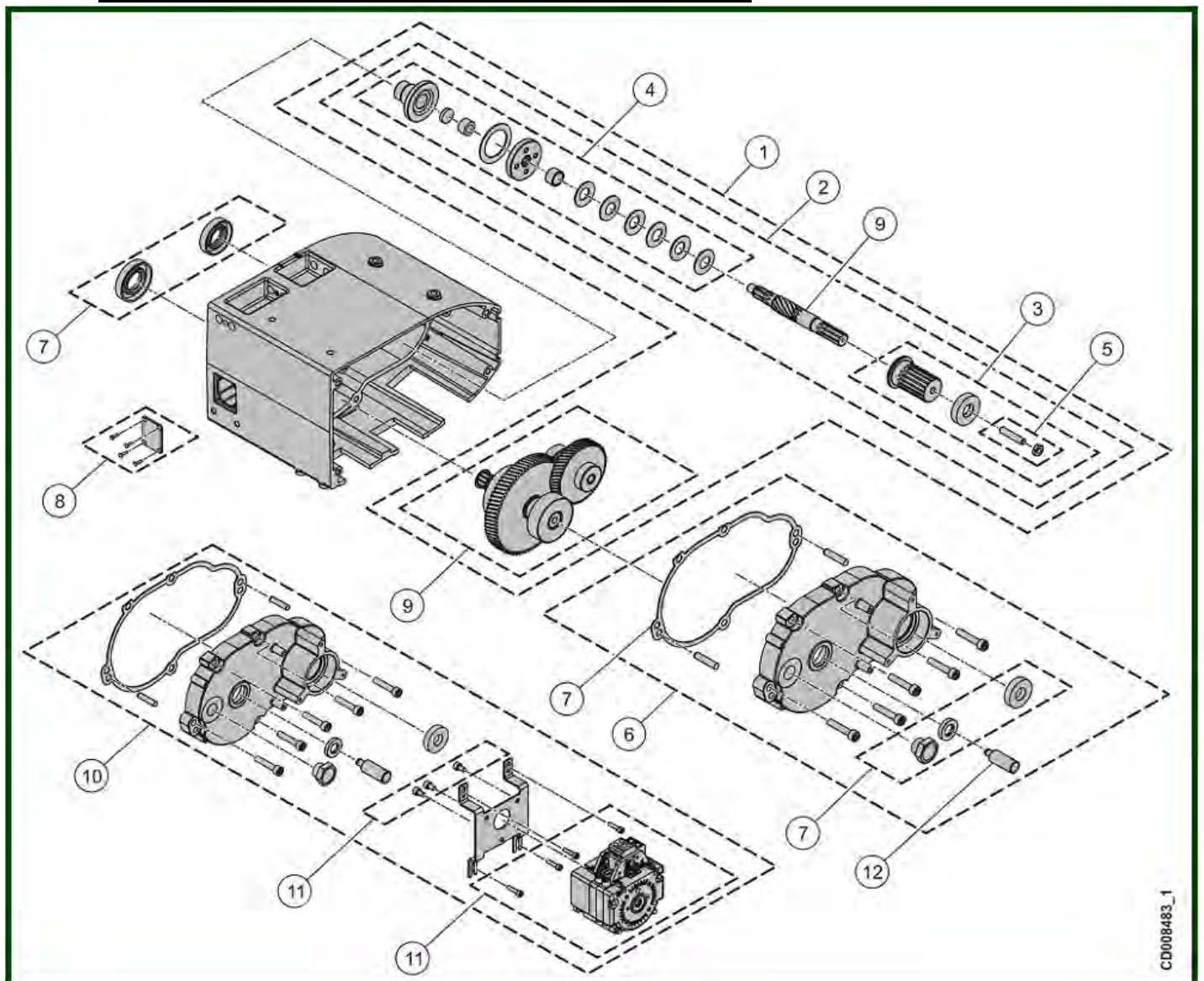



ITEM	REFERENCE	DESCRIPTION
1	VT0007634	Gear - Pinion set, Inferior or equal to 63 kg, 4m/8m/min
1	VT0007635	Gear - Pinion set, Inferior or equal to 63 kg, 10m/min
1	VT0007638	Gear - Pinion set, Inferior or equal to 63 kg, 16m/min
1	VT0007639	Gear - Pinion set, Inferior or equal to 63 kg, 20m/min
1	VT0007646	Gear - Pinion set, Inferior or equal to 63 Kg, 4m/8m/min
1	VT0007647	Gear - Pinion set, Inferior or equal to 63 Kg, 10m/min
1	VT0007648	Gear - Pinion set, Inferior or equal to 63 Kg, 16m/min
1	VT0007649	Gear - Pinion set, Inferior or equal to 63 Kg, 20m/min
2	VT0007651	Gear shaft with clutch, Inferior or equal to 63 Kg, Double brake
2	VT0007640	Gear shaft with clutch, Inferior or equal to 63 Kg, Single brake
3	VT0007641	Coupling - Side brake, Double brake
3	VT0004727	Gear shaft with clutch, Single brake
4	VT0006114	Clutch, Inferior or equal to 63 kg
5	VT0006107	Screw set
6	VT0009112	Gear housing set
7	VT0009113	Seal set
8	VT0005087	End cap, Chain guide
9	VT0004937	Gear assembly, 20m/min
9	VT0004935	Gear assembly, 4/8m/min, Single brake
9	VT0004938	Gear assembly, 10m/min
9	VT0004936	Gear assembly, 16m/min
10	VT0009127	Adaptation set of geared limit switch, 2 steps, VR02F=20m: 1 fall-10m: 2 falls, VR05F=25m: 1 fall-12.5m: 2 falls, VR10F=36m: 1 fall-18m: 2 falls, VR16F=48m: 1 fall-24m: 2 falls, VR25F=56m: 1 fall-28m: 2 falls
10	VT0009128	Adaptation set of geared limit switch, 4 steps, VR02F=20m: 1 fall-10m: 2 falls, VR05F=25m: 1 fall-12.5m: 2 falls, VR10F=36m: 1 fall-18m: 2 falls, VR16F=48m: 1 fall-24m: 2 falls, VR25F=56m: 1 fall-28m: 2 falls
11	VT0006113	Rotating limit switch, 2 steps, VR02=>20m: 1brin, VR05=>25m: 1brin, VR12=>36m: 1 fall - 18m: 2 falls VR16=>48m: 1 fall - 24m: 2 falls, VR25=>56m: 1 fall - 28m: 2 falls
11	VT0006252	Rotating limit switch, 4 steps, VR02=>20m: 1fall, VR05=>25m: 1fall, VR12=>36m: 1 fall - 18m: 2 falls, VR16=>48m: 1 fall - 24m: 2 falls, VR25=>56m: 1 fall - 28m: 2 falls
12	VT0009109	Shaft, For geared limit switch

## 5) MOTOR

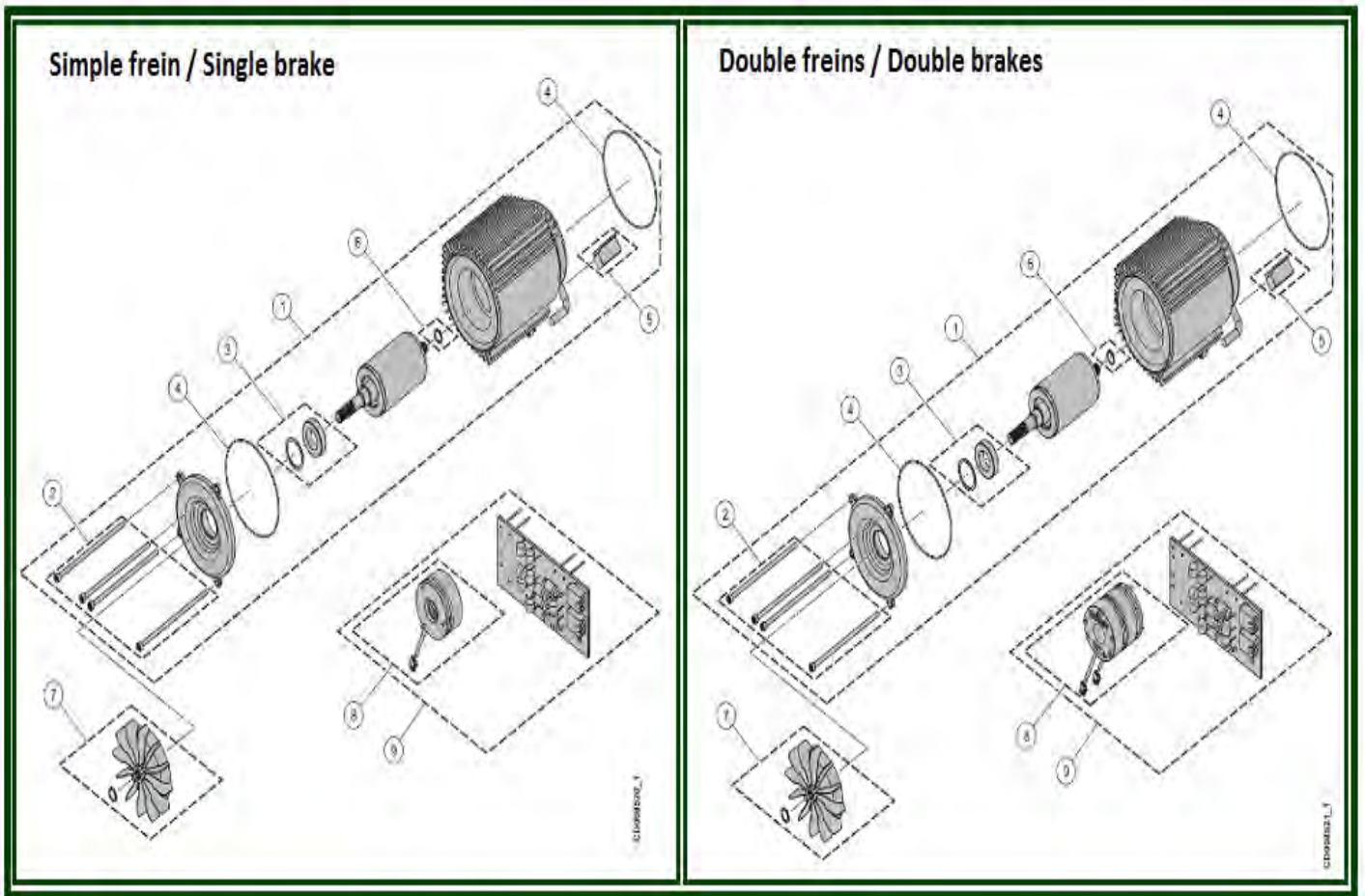

### 5.1) SINGLE BRAKE

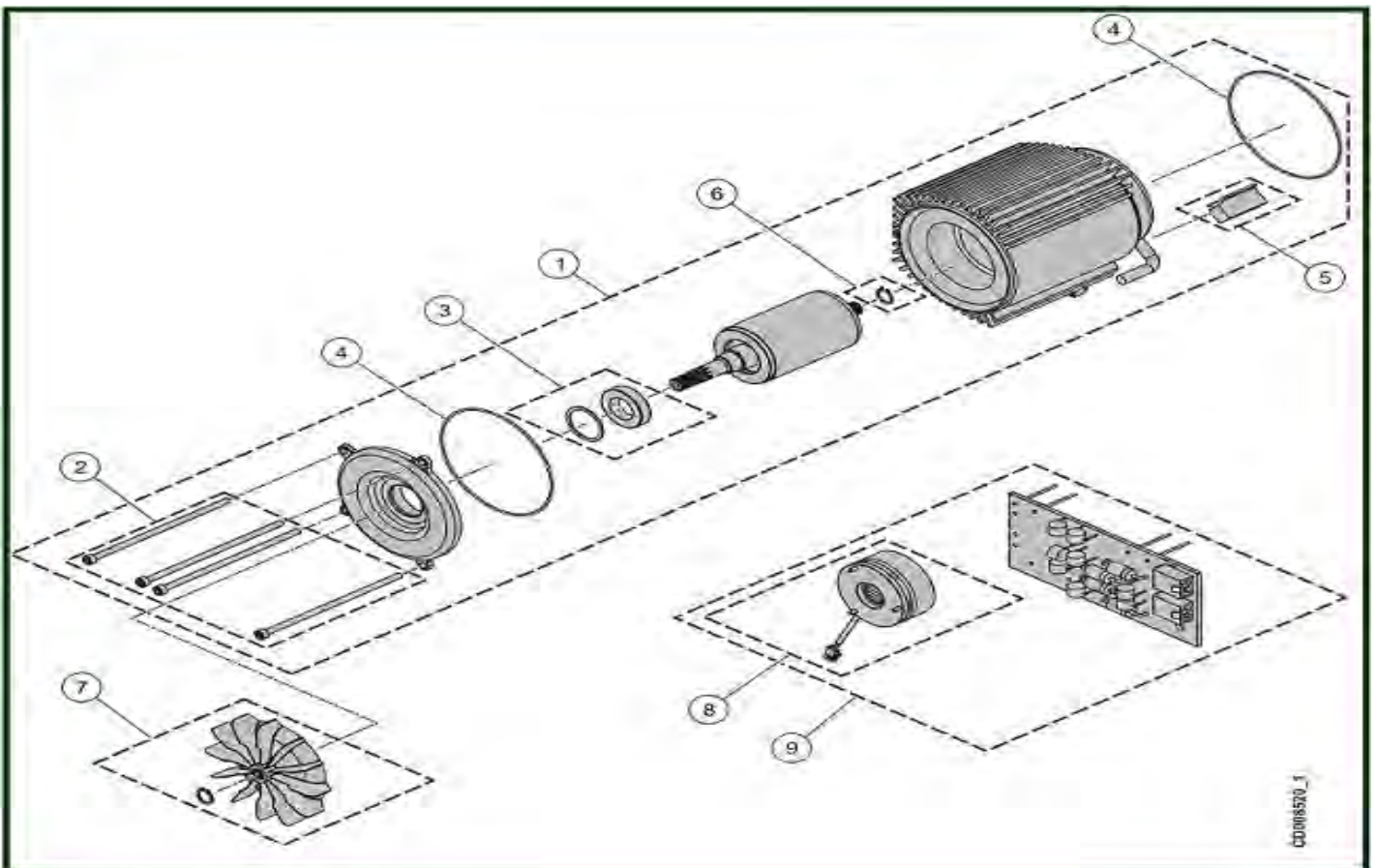

ITEM	REFERENCE	DESCRIPTION
1	VT0009118	Motor - 2 speed, 208-230V 60Hz
1	VT0009115	Motor - 2 speed, 220-240V 50Hz
1	VT0009119	Motor - 2 speed, 380-400V 60Hz
1	VT0009114	Motor - 2 speed, 380-415V 50Hz, 440-480V 60Hz
1	VT0009116	Motor - 2 speed, 500-525V 50Hz, 575-600V 60Hz
1	VT0009117	Motor - 2 speed, 660-690V 50Hz
1	VT0009120	Motor - 2 speeds 660-690V 60Hz
2	VT0005088	Screw set
3	VT0009295	Bearing set
4	VT0009125	Seal
5	VT0009126	Seal grommet
7	VT0004641	Fan set
8	VT0006260	Single brake - 103-230V, USED 208V - 230V
8	VT0004662	Single brake - 190-400V, USED 380V - 480V
9	VT0006261	Single brake + Rectifier, 103V
9	VT0006186	Single brake + Rectifier, 190 V

## 5.2) DOUBLE BRAKES

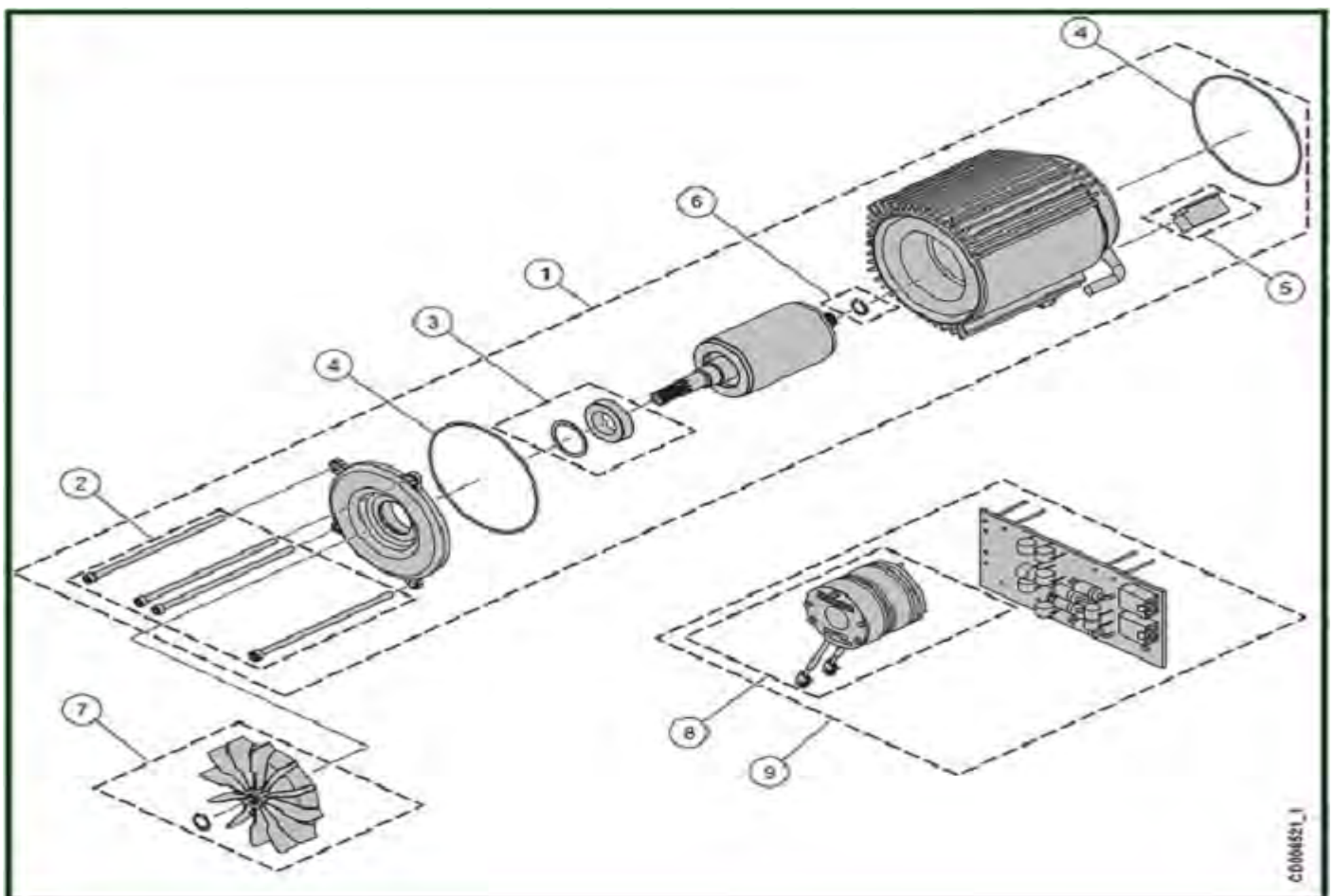



ITEM	REFERENCE	DESCRIPTION
1	VT0009118	Motor - 2 speed, 208-230V 60Hz
1	VT0009115	Motor - 2 speed, 220-240V 50Hz
1	VT0009119	Motor - 2 speed, 380-400V 60Hz
1	VT0009114	Motor - 2 speed, 380-415V 50Hz, 440-480V 60Hz
1	VT0009116	Motor - 2 speed, 500-525V 50Hz, 575-600V 60Hz
1	VT0009117	Motor - 2 speed, 660-690V 50Hz
1	VT0009120	Motor - 2 speed, 660-690V 60Hz
2	VT0005088	Screw set
3	VT0009295	Bearing set
4	VT0009125	Seal
5	VT0009126	Seal grommet
7	VT0004641	Fan set
8	VT0006185	Double brakes, 103 V
8	VT0006184	Double brakes, 190 V
9	VT0006189	Double brakes + Rectifier, 103 V
9	VT0006188	Double brakes + Rectifier, 190 V

## 6) ELECTRICAL PARTS

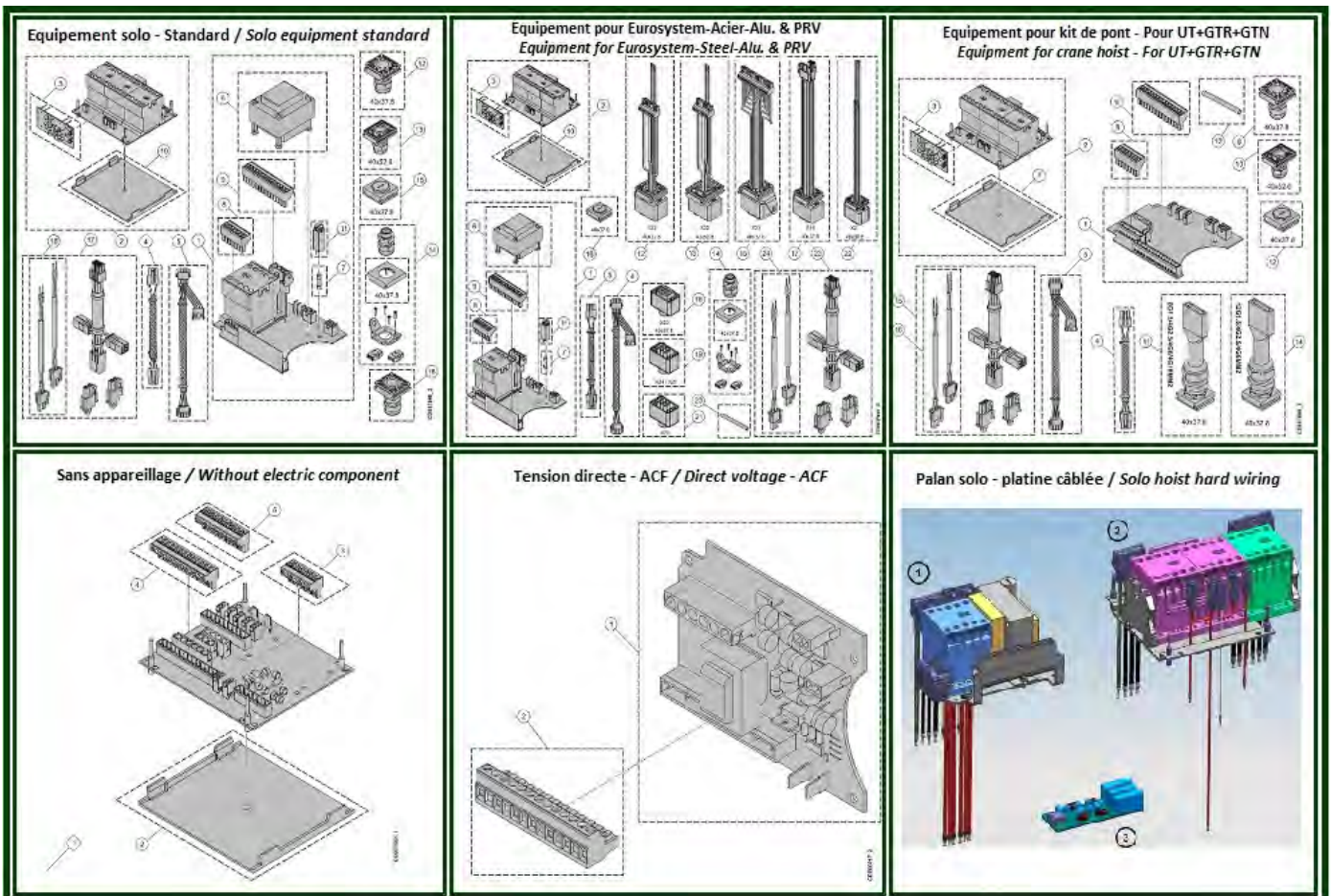



## 6.1) SOLO EQUIPMENT - STANDARD

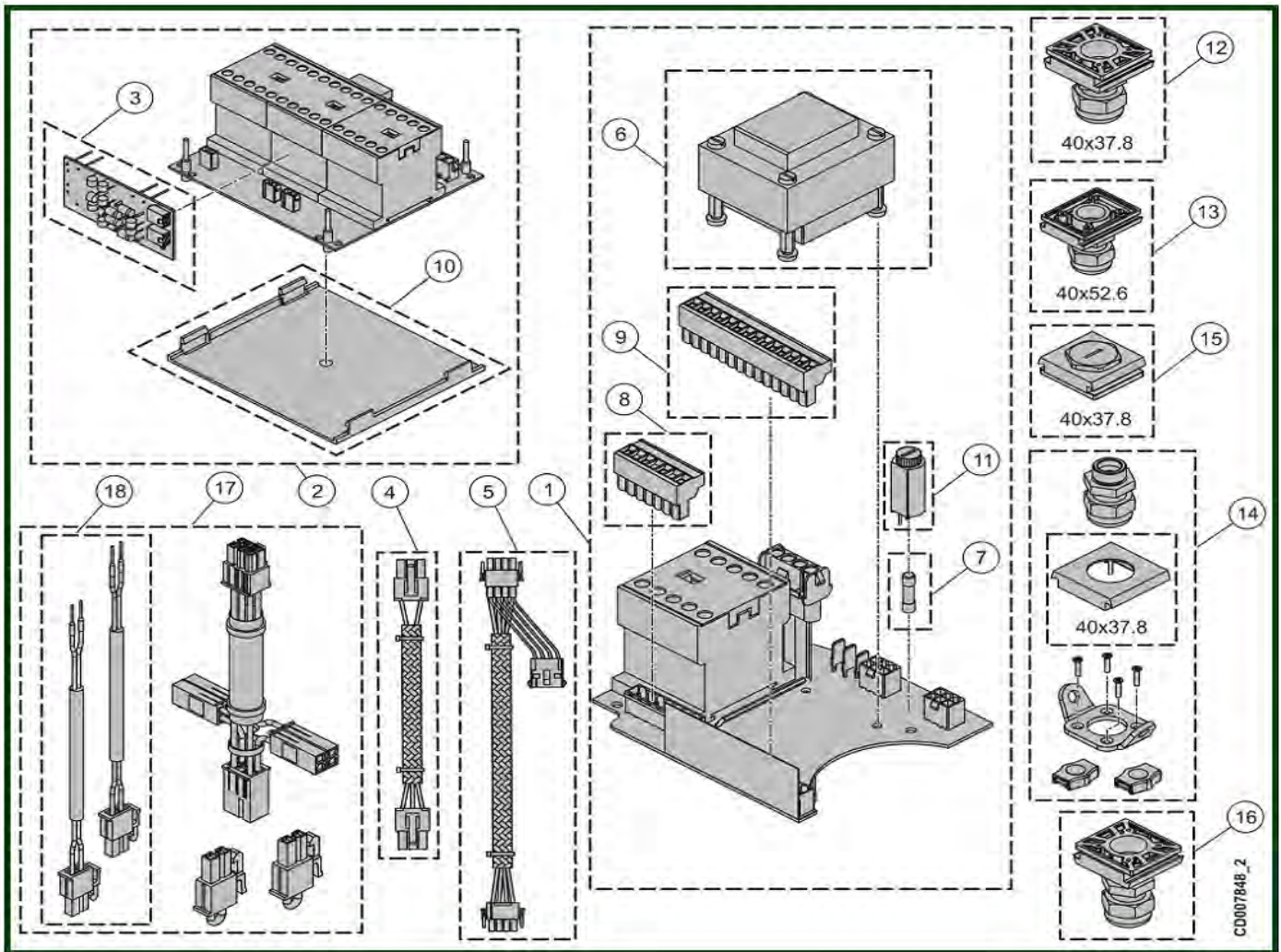

ITEM	REFERENCE	DESCRIPTION
1	VT0006431	Power supply PC Board - Solo hoist, 208V 230V / 110V CI/PC - Standard
1	VT0006430	Power supply PC Board - Solo hoist, 230V / 48V CI/PC - Standard
1	VT0004944	Power supply PC Board - Solo hoist, 400V / 24V CI/PC BOARD
1	VT0004942	Power supply PC Board - Solo hoist, 400V / 48V CI/PC BOARD
1	VT0005312	Power supply PC Board - Solo hoist, 400V / 110V CI/PC BOARD
1	VT0005313	Power supply PC Board - Solo hoist, 400V / 230V CI/PC BOARD
1	VT0006432	Power supply PC Board - Solo hoist, 460V / 48V CI/PC BOARD
1	VT0006433	Power supply PC Board - Solo hoist, 460V / 110V CI/PC BOARD
1	VT0006434	Power supply PC Board - Solo hoist, 500V / 48V CI/PC BOARD
1	VT0006446	Power supply PC Board - Solo hoist, 500V / 110V CI/PC BOARD
1	VT0006435	Power supply PC Board - Solo hoist, 575V / 48V CI/PC BOARD
1	VT0006447	Power supply PC Board - Solo hoist, 575V / 110V CI/PC BOARD
2	VT0005302	Electrical board - 2 speeds - 1 brake, 230V-690V / 24V / 50 60Hz
2	VT0004945	Electrical board - 2 speeds - 1 brake, 230V-690V / 48V / 50-60Hz

2	VT0005303	Electrical board - 2 speeds - 1 brake, 230V-690V / 110V / 50-60Hz
2	VT0005304	Electrical board - 2 speeds - 1 brake, 230V-690V/ 230V / 50 60Hz
2	VT0005305	Electrical board - 2 speeds - 2 brakes, 230V-690V / 24V /50 60Hz
2	VT0005306	Electrical board - 2 speeds - 2 brakes, 230V-690V / 48V / 50 60Hz
2	VT0005307	Electrical board - 2 speeds - 2 brakes, 230V-690V / 50-60Hz
2	VT0005308	Electrical board - 2 speeds - 2 brakes, 230V-690V/ 230V / 50 60Hz
3	VT0004948	Reconnectable rectifier, 208V-690V
3	VT0004946	Rectifier - 1 brake, 230V-690V
3	VT0004947	Rectifier - 2 brakes, 230V-690V
4	VT0004949	Wire harness - Plug control voltage
5	VT0004950	Wire harness - Plug power voltage
6	VT0006439	Transformer, 208V 230V / 115V
6	VT0006325	Transformer, 230V / 48V
6	VT0004952	Transformer, 400V / 24V
6	VT0004953	Transformer, 400V / 48V - 50/60Hz
6	VT0004951	Transformer, 400V / 115V - 50/60Hz
6	VT0004954	Transformer, 400V / 230V
6	VT0006437	Transformer, 460V / 48V
6	VT0006440	Transformer, 460V / 110V 50/60Hz
6	VT0006436	Transformer, 500V / 48V
6	VT0006438	Transformer, 575V / 48V
6	VT0008540	Transformer, 575V / 110V
7	VT0008541	Fuse set, 230V
7	VT0004915	Set of 10 fuses, 48V
7	VT0004955	Set of 10 fuses, 115V
8	VT0005107	Connector, 4P
9	VT0005108	Connector, 14P
10	VT0006441	Insulation plate
11	VT0006191	Fuse base
12	VT0006393	Cable gland set - Square cable entry, CG M20- ISO 20 Trolley-Power supply
13	VT0005089	Cable gland set - Square rectangular entry, Power supply - Only VR2, ISO 20
14	VT0005090	Cable gland set - Square cable entry, Push button
15	VT0006089	End cap - Square cable entry

16	VT0006326	Cable gland set flat cable - Square cable entry, Flat cable 4G2.5
17	VT0008551	Set of connection GLS, FDC MS +GLS
18	VT0008550	GLS cable, Quantity: 2 for 2 steps or 4 for 4 steps
-	VT0006967	Time counter

## 6.2) EQUIPMENT FOR EUROSYSTEM STEEL & ALU. & PRV

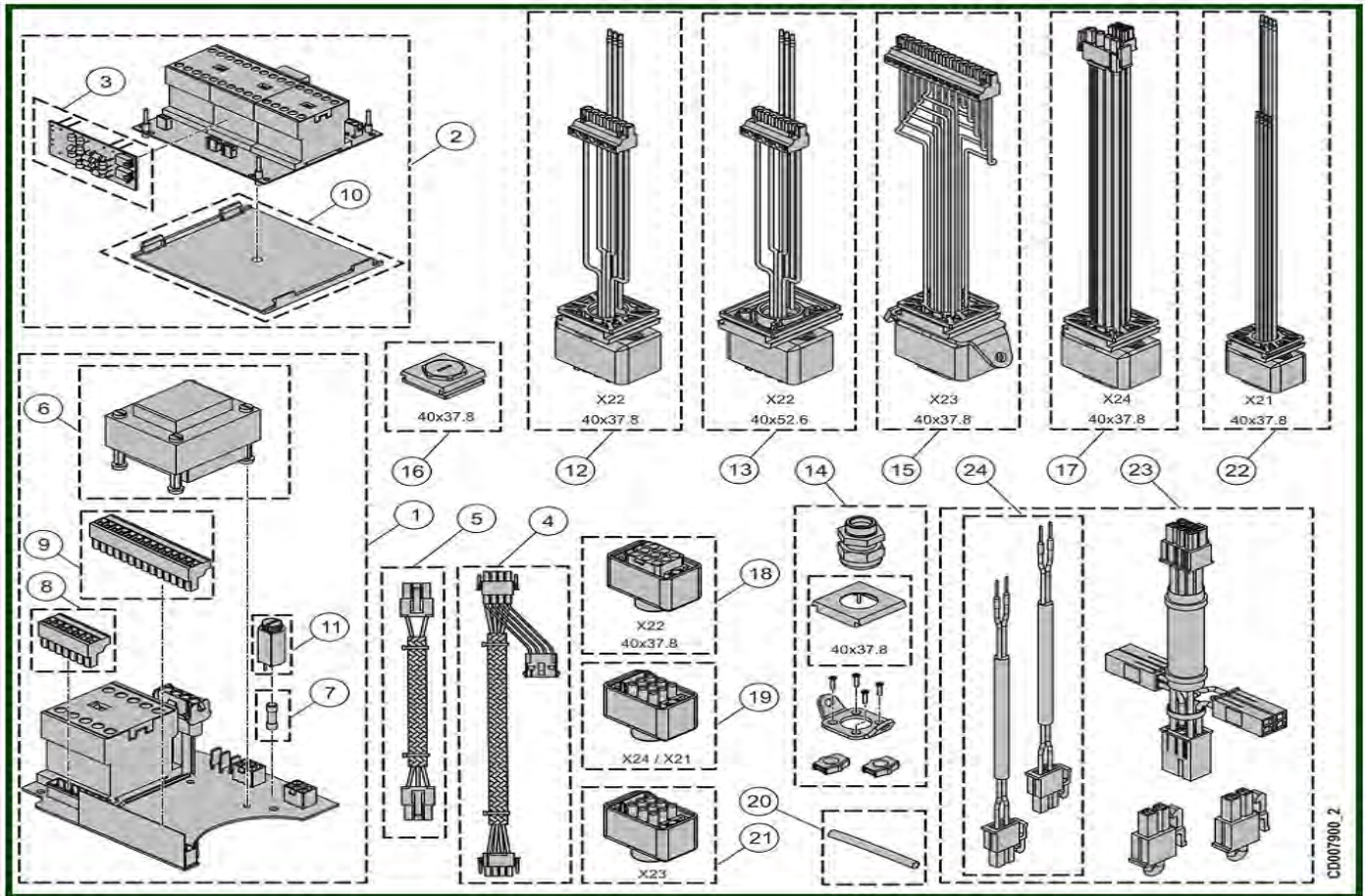

ITEM	REFERENCE	DESCRIPTION
1	VT0006431	Power supply PC Board - Solo hoist, 208V 230V / 110V CI/PC - Standard
1	VT0006430	Power supply PC Board - Solo hoist, 230V / 48V CI/PC - Standard
1	VT0004944	Power supply PC Board - Solo hoist, 400V / 24V CI/PC BOARD
1	VT0004942	Power supply PC Board - Solo hoist, 400V / 48V CI/PC BOARD
1	VT0005312	Power supply PC Board - Solo hoist, 400V / 110V CI/PC BOARD
1	VT0005313	Power supply PC Board - Solo hoist, 400V / 230V CI/PC BOARD
1	VT0006432	Power supply PC Board - Solo hoist, 460V / 48V CI/PC BOARD
1	VT0006433	Power supply PC Board - Solo hoist, 460V / 110V CI/PC BOARD
1	VT0006434	Power supply PC Board - Solo hoist, 500V / 48V CI/PC BOARD
1	VT0006446	Power supply PC Board - Solo hoist, 500V / 110V CI/PC BOARD
1	VT0006435	Power supply PC Board - Solo hoist, 575V / 48V CI/PC BOARD

1	VT0006447	Power supply PC Board - Solo hoist, 575V / 110V CI/PC BOARD
2	VT0005302	Electrical board - 2 speeds - 1 brake, 230V-690V / 24V / 50 60Hz
2	VT0004945	Electrical board - 2 speeds - 1 brake, 230V-690V / 48V / 50-60Hz
2	VT0005303	Electrical board - 2 speeds - 1 brake, 230V-690V / 110V / 50-60Hz
2	VT0005304	Electrical board - 2 speeds - 1 brake, 230V-690V/ 230V / 50 60Hz
2	VT0005305	Electrical board - 2 speeds - 2 brakes, 230V-690V / 24V /50 60Hz
2	VT0005306	Electrical board - 2 speeds - 2 brakes, 230V-690V / 48V / 50 60Hz
2	VT0005307	Electrical board - 2 speeds - 2 brakes, 230V-690V / 50-60Hz
2	VT0005308	Electrical board - 2 speeds - 2 brakes, 230V-690V/ 230V / 50 60Hz
3	VT0004946	Rectifier - 1 brake, 230V-690V
3	VT0004947	Rectifier - 2 brakes, 230V-690V
4	VT0004949	Wire harness - Plug control voltage
5	VT0004950	Wire harness - Plug power voltage
6	VT0006439	Transformer, 208V 230V / 115V
6	VT0006325	Transformer, 230V / 48V
6	VT0004952	Transformer, 400V / 24V
6	VT0004953	Transformer, 400V / 48V - 50/60Hz
6	VT0004951	Transformer, 400V / 115V - 50/60Hz
6	VT0004954	Transformer, 400V / 230V
6	VT0006437	Transformer, 460V / 48V
6	VT0006440	Transformer, 460V / 110V 50/60Hz
6	VT0006436	Transformer, 500V / 48V
6	VT0006438	Transformer, 575V / 48V
6	VT0008540	Transformer, 575V / 110V
7	VT0008541	Fuse set, 230V
7	VT0004915	Set of 10 fuses, 48V
7	VT0004955	Set of 10 fuses, 115V
8	VT0005107	Connector, 4P
9	VT0005108	Connector, 14P
10	VT0006441	Insulation plate
11	VT0006191	Fuse base
12	VT0007798	Power supply connector set square, X22 Side hoist
13	VT0007574	Power supply connector set rectangular, X22 Side hoist - Only VR2



14	VT0005090	Cable gland set - Square cable entry, Push button
15	VT0007224	Push button connector set, X23 Side hoist - Movable push button only
16	VT0006089	End cap - Square cable entry
17	VT0006971	Trolley connector set, X24 Side hoist
18	VT0007804	Power supply connector set, X22 Side flat cable
19	VT0007805	Trolley connector set, X24 Side flat cable
20	VT0007781	Head shrinkable tube
21	VT0007806	Push button connector set, X23 Side push button-Movable push button only
22	VT0008135	Crane cubicle connector set, X21 Side hoist
23	VT0008551	Set of connection GLS, FDC MS +GLS
24	VT0008550	GLS cable, Quantity: 2 for 2 steps or 4 for 4 steps
-	VT0006967	Time counter

### 6.3) EQUIPMENT FOR CRANE KIT - FOR UT+GTR+GTN

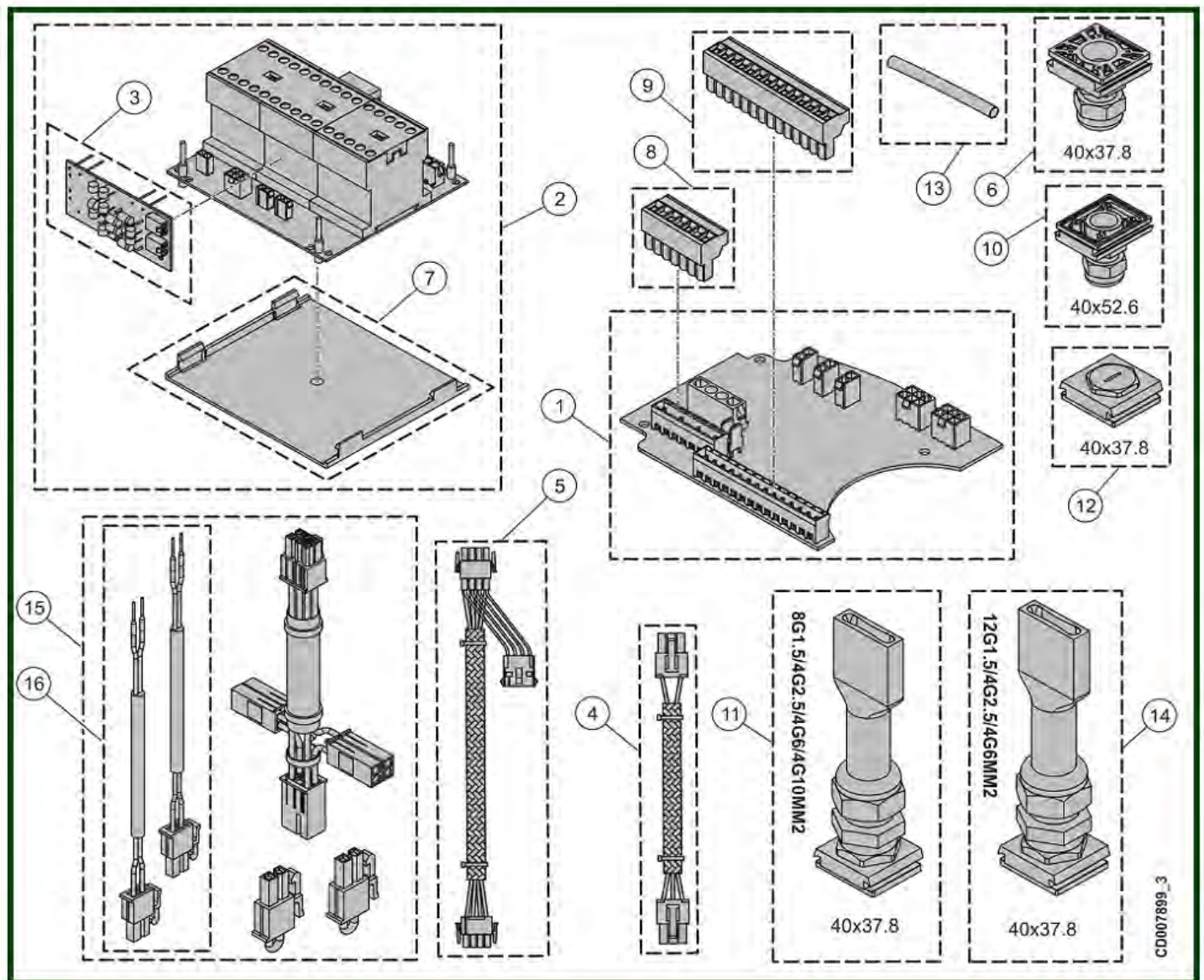

ITEM	REFERENCE	DESCRIPTION
1	VT0004943	Electrical power crane,230V-690V CI/PC BOARD
2	VT0005302	Electrical board - 2 speed - 1 brake, 230V-690V / 24V / 50 60Hz
2	VT0004945	Electrical board - 2 speed - 1 brake, 230V-690V / 48V / 50-60Hz
2	VT0005303	Electrical board - 2 speed - 1 brake, 230V-690V / 110V / 50-60Hz
2	VT0005304	Electrical board - 2 speed - 1 brake, 230V-690V/ 230V / 50 60Hz
2	VT0005305	Electrical board - 2 speed - 2 brakes, 230V-690V / 24V /50 60Hz
2	VT0005306	Electrical board - 2 speed - 2 brakes, 230V-690V / 48V / 50 60Hz
2	VT0005307	Electrical board - 2 speed - 2 brakes, 230V-690V / 50-60Hz
2	VT0005308	Electrical board - 2 speed - 2 brakes, 230V-690V/ 230V / 50 60Hz
3	VT0004946	Rectifier - 1 brake, 230V-690V
3	VT0004947	Rectifier - 2 brakes, 230V-690V
4	VT0004949	Wire harness - Plug control voltage
5	VT0004950	Wire harness - Plug power voltage
6	VT0006393	Cable gland set - Square cable entry, CG M20- ISO 20 Trolley-Power supply
7	VT0006441	Insulation plate
8	VT0005107	Connector, 4P
9	VT0005108	Connector, 14P
10	VT0007782	Cable gland set - Rectangular cable entry, 4G2.5MM2, Flat cable - Only VR2
11	VT0007780	Square flat cable connector set, 8G1.5/4G2.5/4G6/4G10mm2
12	VT0006089	End cap - Square cable entry
13	VT0007781	Head shrinkable tube
14	VT0006454	Cable gland set flat cable-Square cable entry 12G1.5/4G2.5/4G6mm2-ISO 25
15	VT0008551	Set of connection GLS, FDC MS +GLS
16	VT0008550	GLS cable, Quantity: 2 for 2 steps or 4 for 4 steps
-	VT0006967	Time counter

#### **6.4) WITHOUT ELECTRIC COMPONENT**

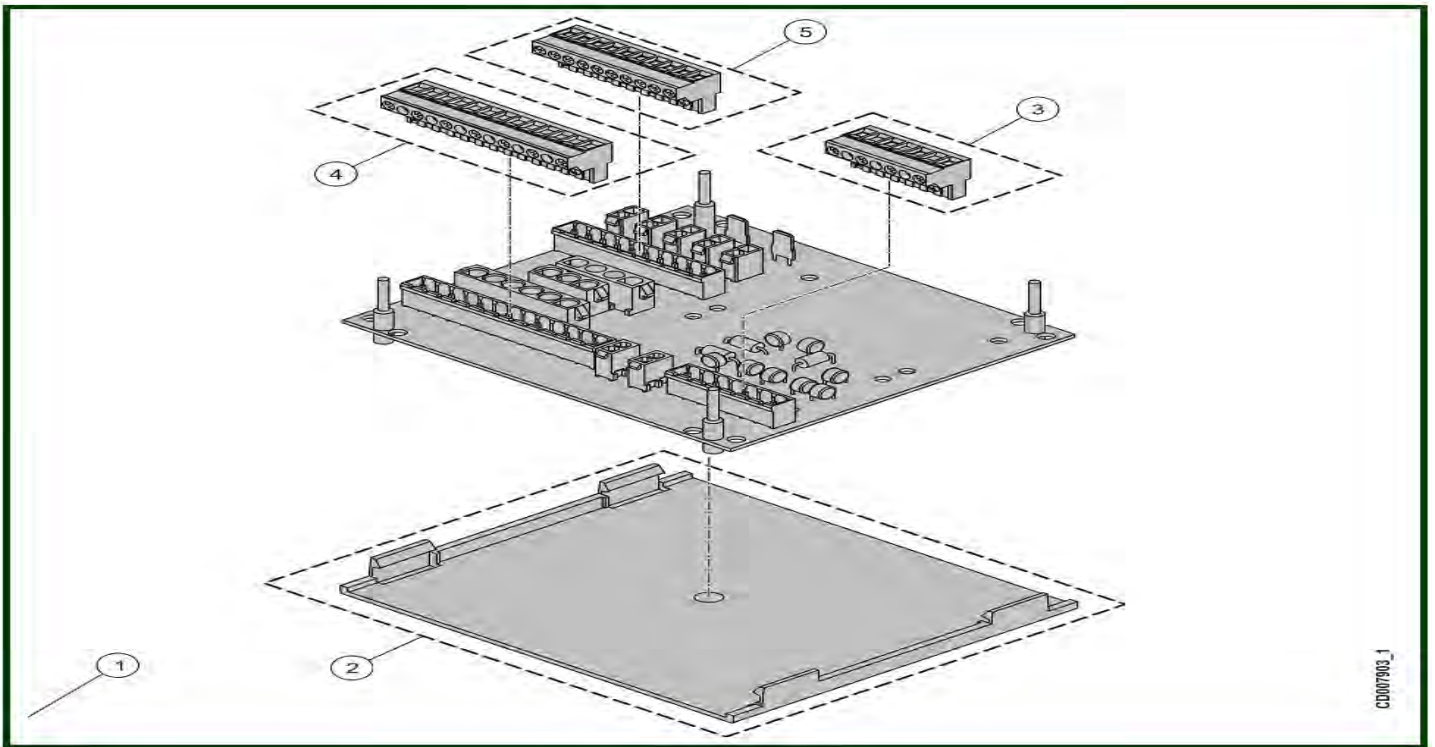

CD007903\_1

ITEM	REFERENCE	DESCRIPTION
1	VT0007656	Electrical board, Without arrangement + Rectifier
2	VT0006441	Insulation plate
3	VT0005107	Connector, 4P
4	VT0006429	Power connector, 7P
5	VT0009330	Control connector, 10P

### 6.5) DIRECT VOLTAGE - ACF

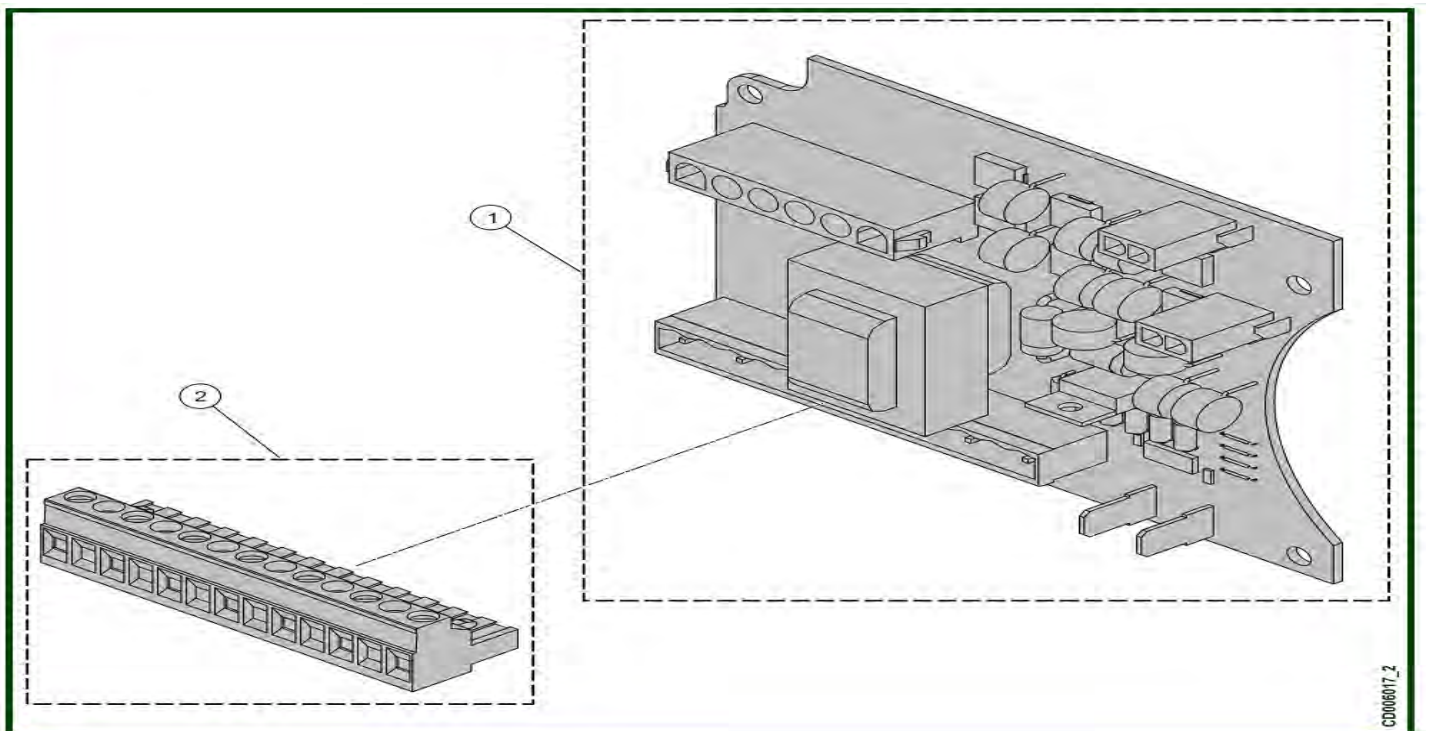

CD006017\_2



ITEM	REFERENCE	DESCRIPTION
1	VT0006428	ACF card - 2 speeds
2	VT0006429	Power connector, 7P

### 6.6) SOLO HOIST - HARD WIRING

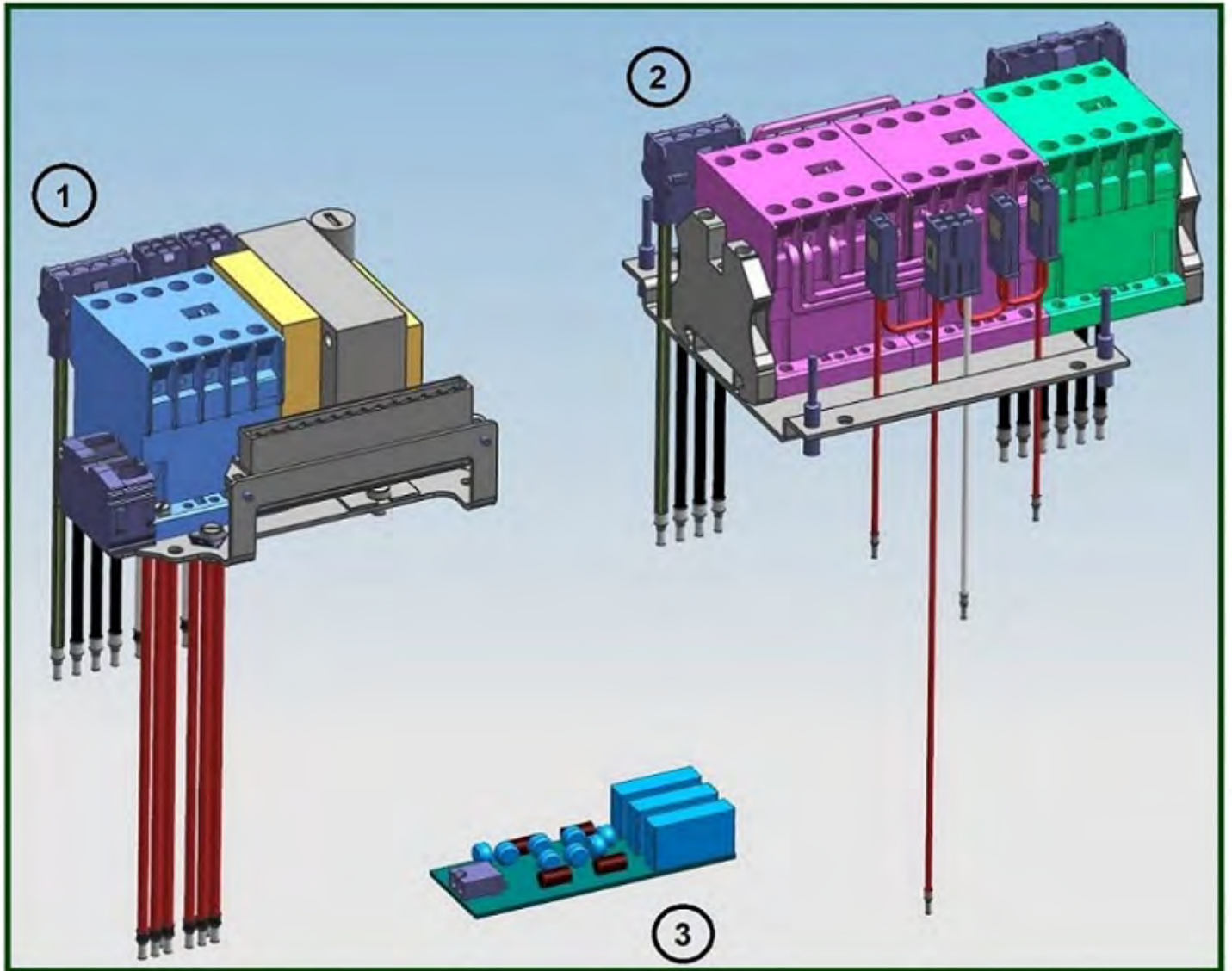

ITEM	REFERENCE	DESCRIPTION
1	VT0007058	Power supply PC Board - Solo hoist, 400V-48V, Hard wiring - Option
1	VT0007084	Power supply PC Board - Solo hoist, 400V-110V, Hard wiring - Option
1	VT0007086	Power supply PC Board - Solo hoist, 460V-48V, Hard wiring - Option
1	VT0007087	Power supply PC Board - Solo hoist, 460V-110V, Hard wiring - Option
2	VT0007057	Electric board 2 speed-1 brake 208V-575V /48V, Hard wiring - Option
2	VT0007089	Electric board 2 speed-1 brake 208V-575V /110V-115V, Hard wiring - Option
3	VT0008823	Rectifier, 208V-575V



## 7) PUSH BUTTON CONTROLLER

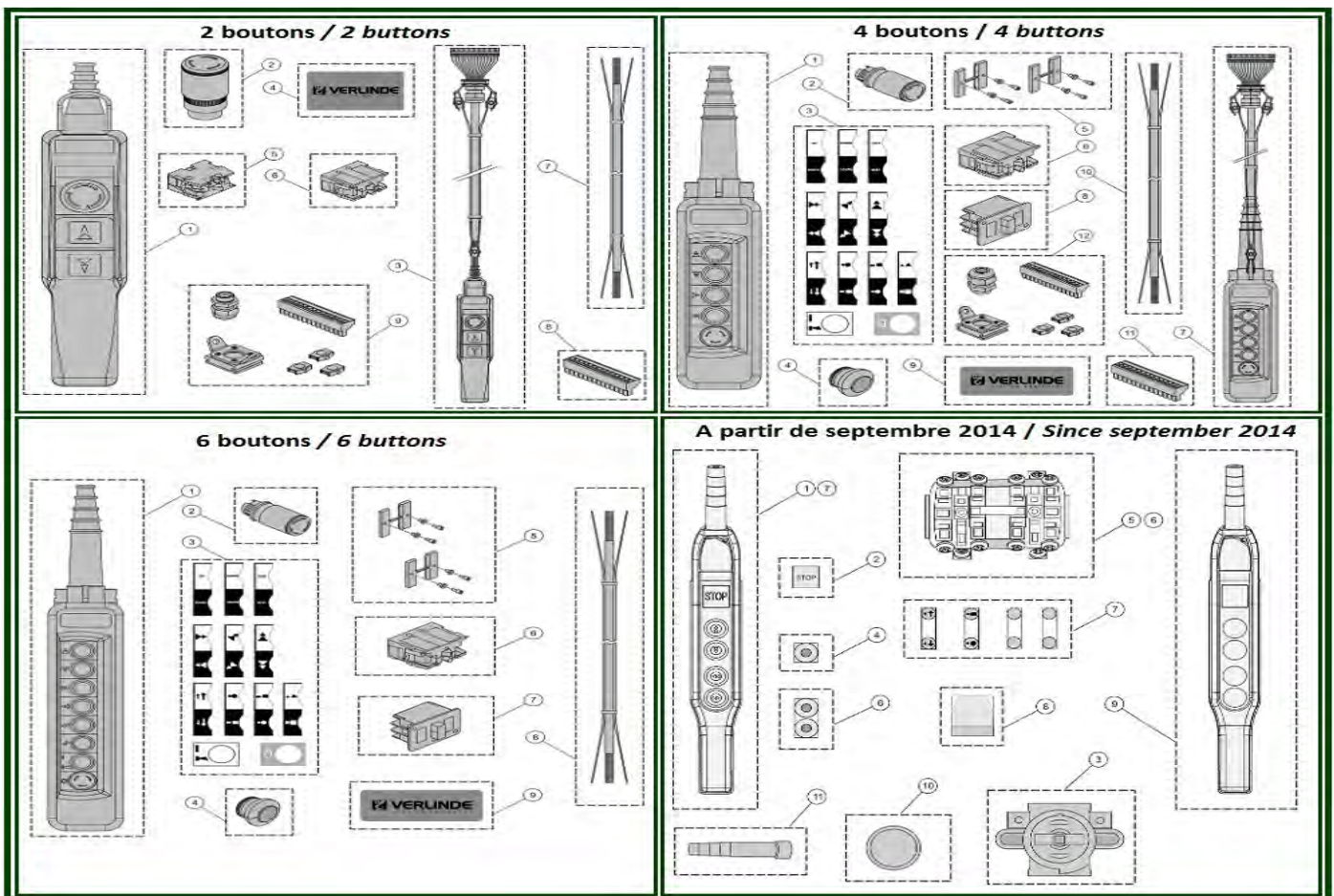

### 7.1) 2 BUTTONS

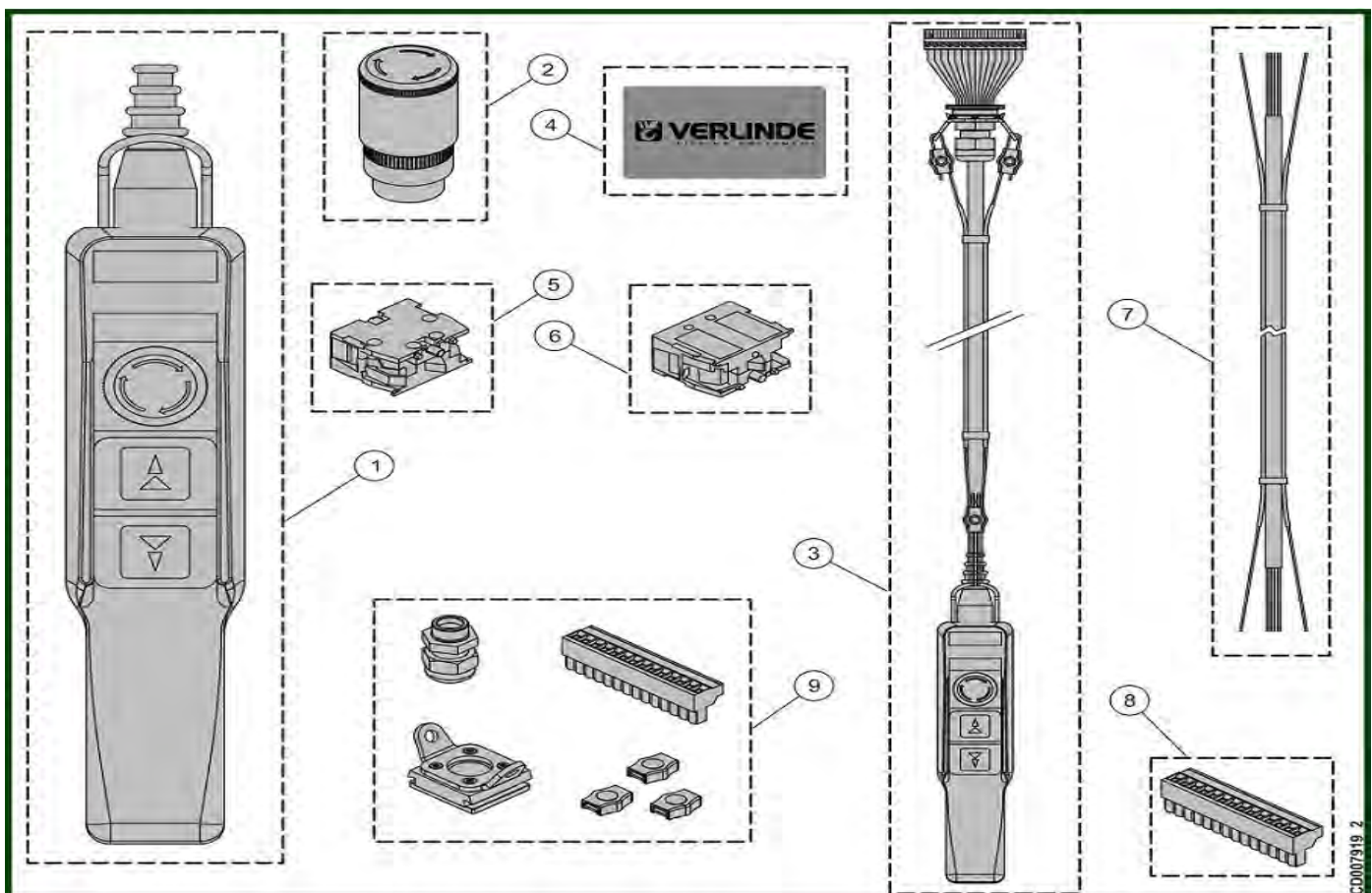

ITEM	REFERENCE	DESCRIPTION
1	VT0005061	Pendant controller - 2HS+ES, Yellow
2	VT0006547	Emergency push button
3	VT0005612	Pendant with cable - 2HS+ES, 2,2 m - Yellow - CE
3	VT0005613	Pendant with cable - 2HS+ES, 2,7 m - Yellow - CE
3	VT0005614	Pendant with cable - 2HS+ES, 3,2 m - Yellow - CE
3	VT0005615	Pendant with cable - 2HS+ES, 3,7 m - Yellow - CE
3	VT0005616	Pendant with cable - 2HS+ES, 4,2 m - Yellow - CE
3	VT0005617	Pendant with cable - 2HS+ES, 4,7 m - Yellow - CE
3	VT0005618	Pendant with cable - 2HS+ES, 5,2 m - Yellow - CE
3	VT0005619	Pendant with cable - 2HS+ES, 5,7 m - Yellow - CE
4	VT0007837	Branding sticker, VERLINDE
5	VT0005064	Contact block, ZB2-BE101
6	VT0005066	Contact block, ZB2-BE 102
7	VT0006746	Cable, 5x1,5 mm <sup>2</sup> - CE
8	VT0005108	Connector, 14P
9	VT0007583	Pendant plug set, ISO

## 7.2) 4 BUTTONS

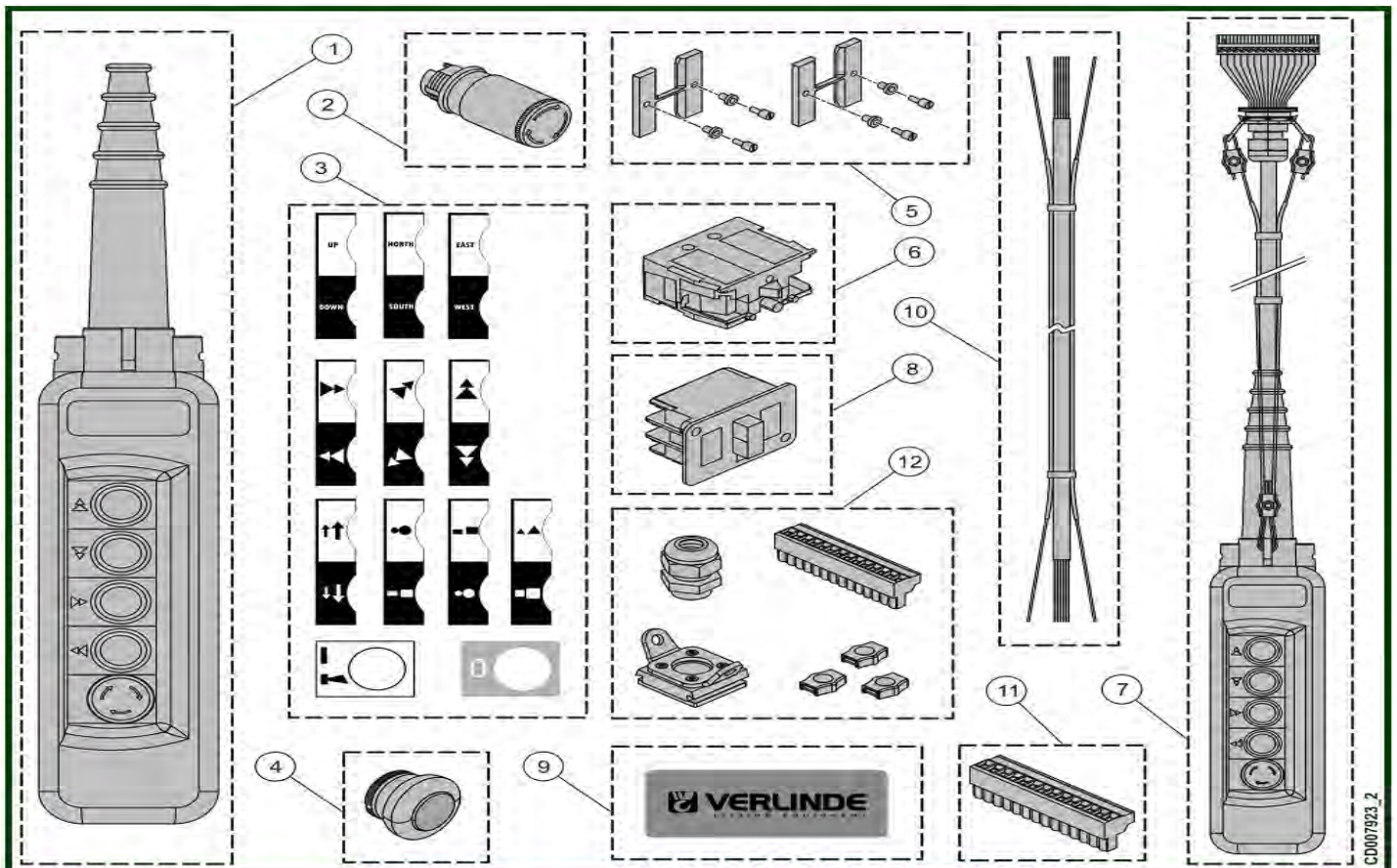



ITEM	REFERENCE	DESCRIPTION
1	VT0005055	Pendant controller, 2HS+2TS+ES, Yellow
2	VT0006548	Emergency push button
3	VT0007882	Set of direction symbols
4	VT0005063	Push button
5	VT0005072	Mechanical interlock
6	VT0005066	Contact block, ZB2-BE 102
7	VT0006060	Pendant with cable, 2HS+2TS+ES, 4,7 m - Yellow
7	VT0006055	Pendant with cable, 2HS+2TS+ES, 2,2 m - Yellow
7	VT0006061	Pendant with cable, 2HS+2TS+ES, 5,2 m - Yellow
7	VT0006056	Pendant with cable, 2HS+2TS+ES, 2,7 m - Yellow
7	VT0006059	Pendant with cable, 2HS+2TS+ES, 4,2 m - Yellow
7	VT0006062	Pendant with cable, 2HS+2TS+ES, 5,7 m - Yellow
7	VT0006057	Pendant with cable, 2HS+2TS+ES, 3,2 m - Yellow
7	VT0006058	Pendant with cable, 2HS+2TS+ES, 3,7 m - Yellow
8	VT0007879	Contact block, XENG1191
9	VT0007880	Sticker of brand, VERLINDE
10	VT0006747	Cable - 8x1,5mm <sup>2</sup> , meter
11	VT0005108	Connector, 14P
12	VT0007583	Pendant plug set, ISO

### 7.3) 6 BUTTONS

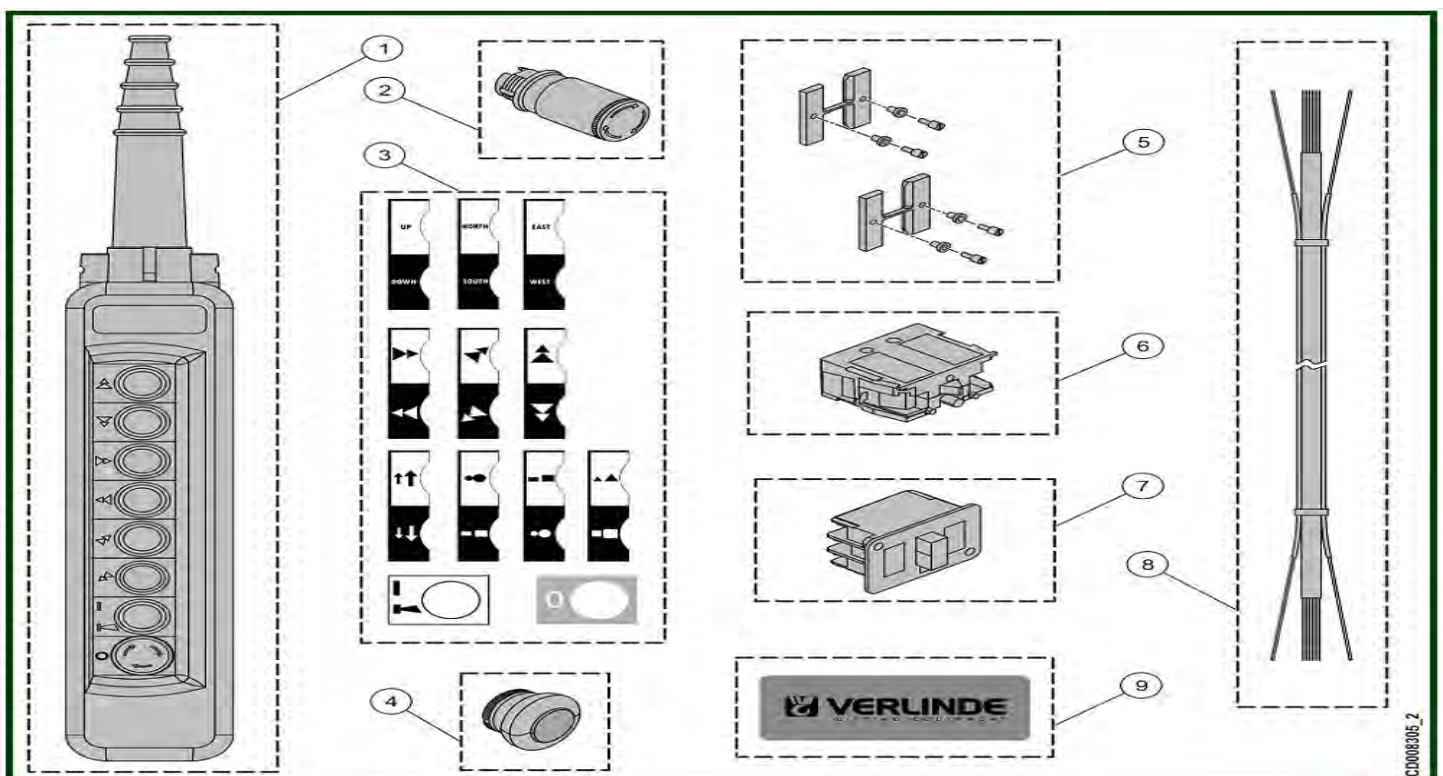

ITEM	REFERENCE	DESCRIPTION
1	VT0005058	Pendant controller, 2HS+2TS+2LS+ON-OFF, Yellow
2	VT0006548	Emergency push button
3	VT0007882	Set of direction symbols
4	VT0005063	Push button
5	VT0005072	Mechanical interlock
6	VT0005066	Contact block, ZB2-BE 102
7	VT0007879	Contact block, XENG1191
8	VT0008073	Cable, 16x1.52mm <sup>2</sup> - metre
8	VT0008074	Cable, 20x1.5mm <sup>2</sup> - metre
9	VT0007880	Sticker of brand, VERLINDE
-	VT0005108	Connector, 14P

#### **7.4) PUSH BUTTON CONTROLLER - FROM SEPTEMBER 2014**

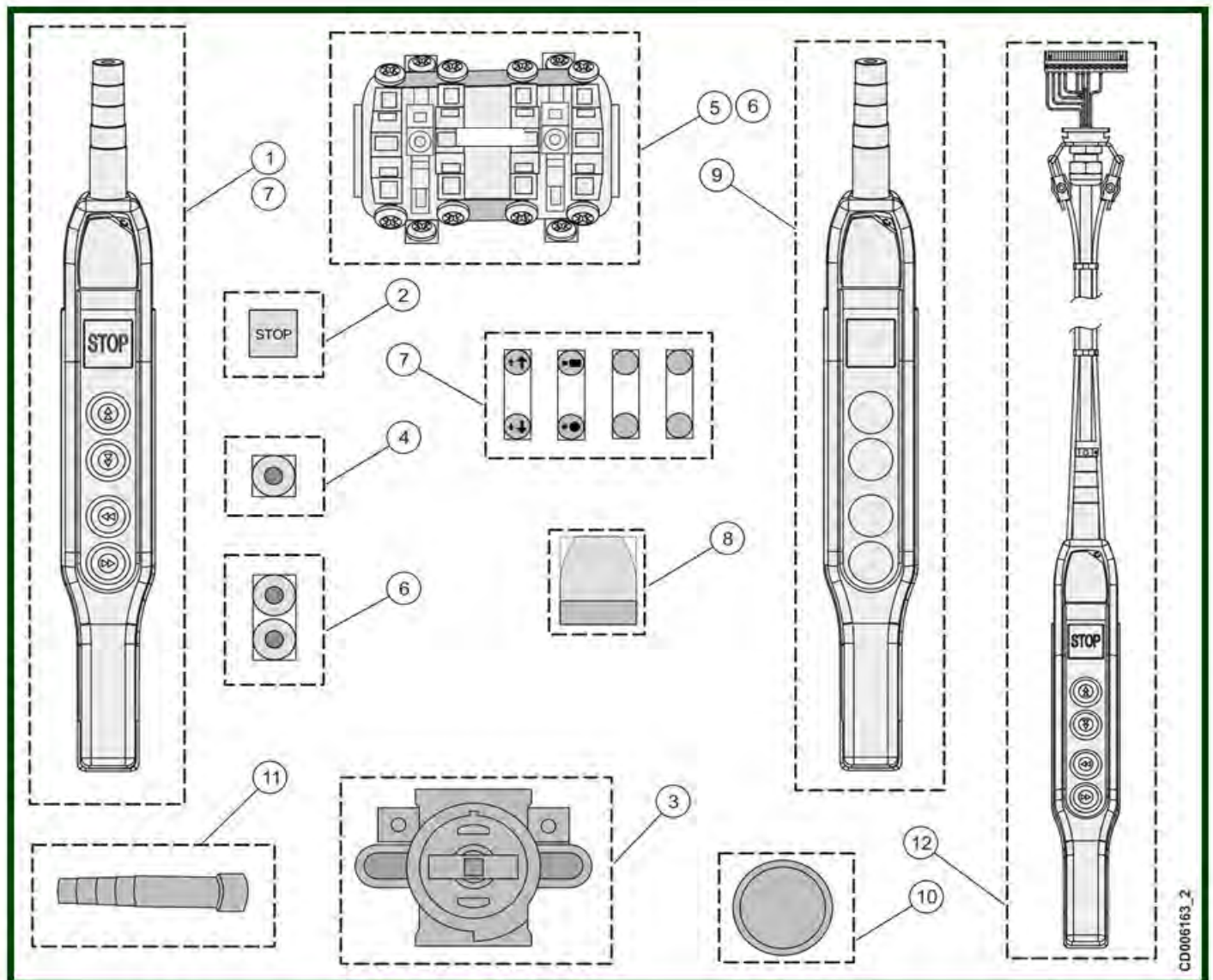



ITEM	REFERENCE	DESCRIPTION
1	VT0006495	Push button box - 2 HS+2TS+ES, Yellow - 4 buttons
1	VT0006493	Push button box - 2 HS+ES, Yellow - 2 buttons
2	VT0006509	Emergency push button
3	VT0006510	Emergency stop contact block
4	VT0006511	Rubber push button
5	VT0006513	Contact block, 2 step
6	VT0006514	Set of 2 push buttons + contact block
7	VT0006754	Stickers - Direction symbols, ANSI
7	VT0006752	Stickers - Direction symbols, DIN
7	VT0006753	Stickers - Direction symbols, FIN-SEN
8	VT0006496	Stickers – Brand, VERLINDE
9	VT0006515	Pendant housing, Yellow - 2 buttons
9	VT0006518	Pendant housing, Yellow - 4 buttons
10	VT0006517	Magnet
10	VT0006516	Rubber part
11	VT0007032	Cable bushing
12	VT0006958	Push button box + cable + plug - 2 HS+ES, 2,20 m - yellow - DIN
12	VT0006951	Push button box + cable + plug - 2 HS+ES, 2,70 m - yellow - DIN
12	VT0006952	Push button box + cable + plug - 2 HS+ES, 3,20 m - yellow - DIN
12	VT0006953	Push button box + cable + plug - 2 HS+ES, 3,70 m - yellow - DIN
12	VT0006954	Push button box + cable + plug - 2 HS+ES, 4,20 m - yellow - DIN
12	VT0006955	Push button box + cable + plug - 2 HS+ES, 4,70 m - yellow - DIN
12	VT0006956	Push button box + cable + plug - 2 HS+ES, 5,20 m - yellow - DIN
12	VT0006957	Push button box + cable + plug - 2 HS+ES, 5,70 m - yellow - DIN
13	VT0006959	Push button box + cable + plug - 2 HS+2TS+ES, 2,20 m - yellow - DIN
13	VT0006966	Push button box + cable + plug - 2 HS+2TS+ES, 2,70 m - yellow - DIN
13	VT0006960	Push button box + cable + plug - 2 HS+2TS+ES, 3,20 m - yellow - DIN
13	VT0006961	Push button box + cable + plug - 2 HS+2TS+ES, 3,70 m - yellow - DIN
13	VT0006962	Push button box + cable + plug - 2 HS+2TS+ES, 4,20 m - yellow - DIN
13	VT0006963	Push button box + cable + plug - 2 HS+2TS+ES, 4,70 m - yellow - DIN
13	VT0006964	Push button box + cable + plug - 2 HS+2TS+ES, 5,20 m - yellow - DIN
13	VT0006965	Push button box + cable + plug - 2 HS+2TS+ES, 5,70 m - yellow - DIN

## 8) NORMAL HEADROOM TROLLEY

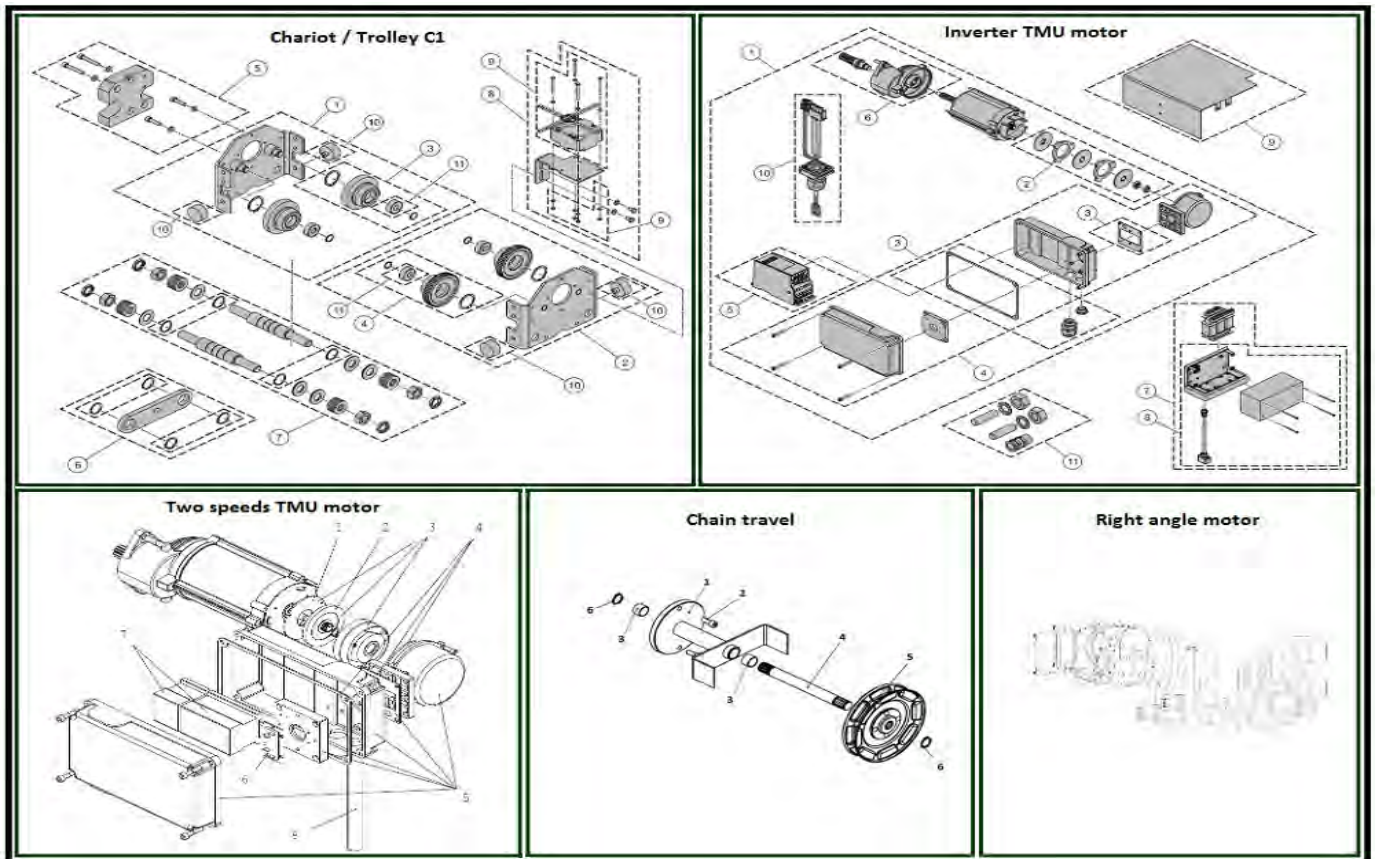

### 8.1) C1 TROLLEY - 0 TO 1000 KG - COUPLED VERSION

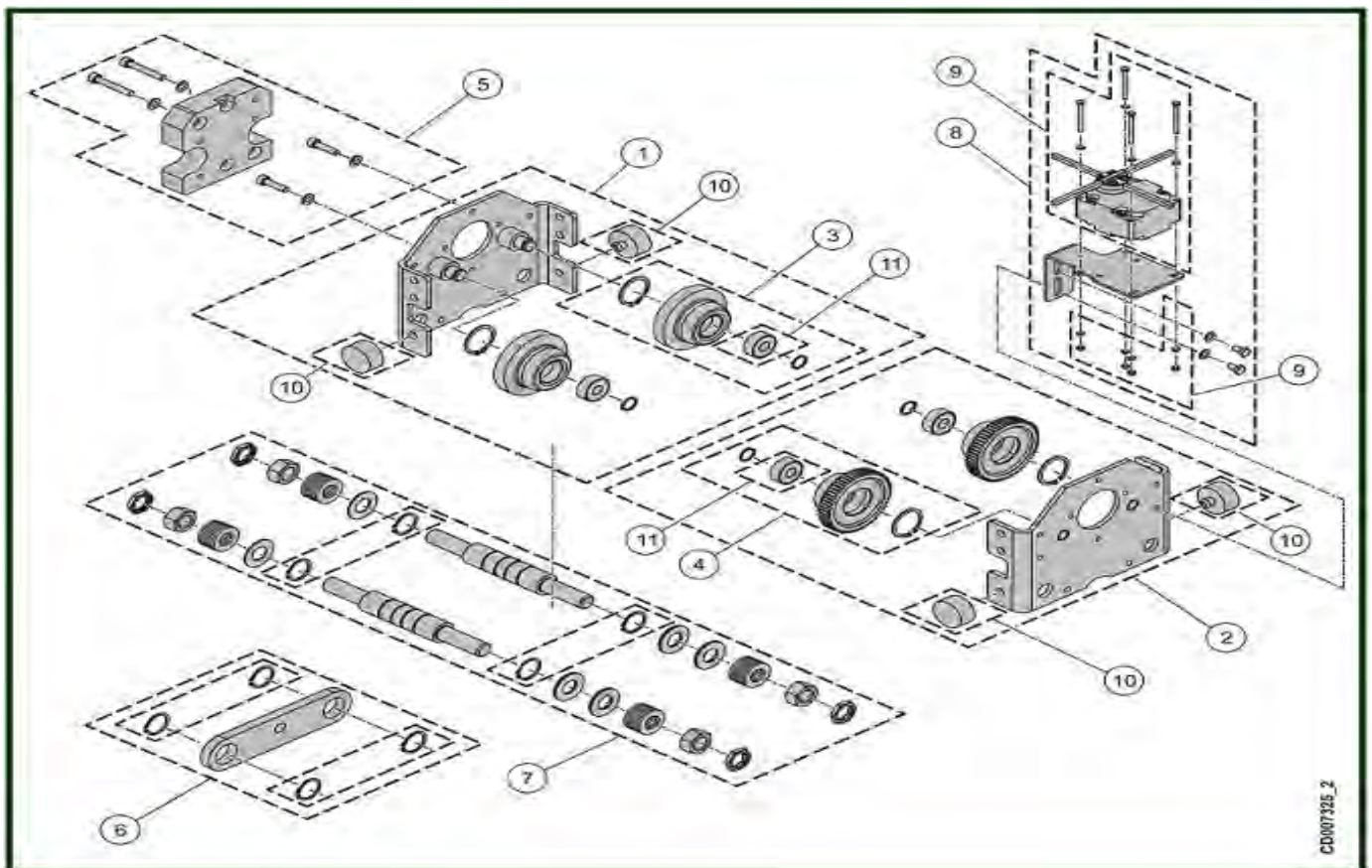

ITEM	REFERENCE	DESCRIPTION
1	VT0007051	Idler side plate assembly
2	VT0007066	Drive side plate assembly
3	VT0007061	Complete set of travel wheel without shaft
4	VT0007063	Set driving wheel without shaft $\varnothing$ 62 - 93 mm
5	VT0007062	Set of counterweights
6	VT0007065	Cross bar, Coupled version
7	VT0007026	Tie rod set beam 55-100mm Monobloc since 1999 Hook/coupling suspension
7	VT0007027	Tie rod set beam 106-150mm Monobloc since 1999 Hook/coupling suspension
7	VT0007028	Tie rod set beam 155-200mm Monobloc since 1999 Hook/coupling suspension
7	VT0007029	Tie rod set beam 206-248mm Monobloc since 1999 Hook/coupling suspension
7	VT0007030	Tie rod set beam 260-307mm Monobloc since 1999 Hook/coupling suspension
7	VT0007031	Tie rod set beam 308-310mm Monobloc since 1999 Hook/coupling suspension
8	VT0007098	Limit switch - 1 step
8	VT0008775	Limit switch - 2 step
9	VT0008776	Travelling limit switch assembly - 1 step
9	VT0008777	Travelling limit switch assembly - 2 step
10	VT0009357	Buffer, D40x20 - For C1 to C5 trolley
11	VT0007091	Ball Bearing

## 8.2) INVERTER TMU MOTOR FOR VR HOIST

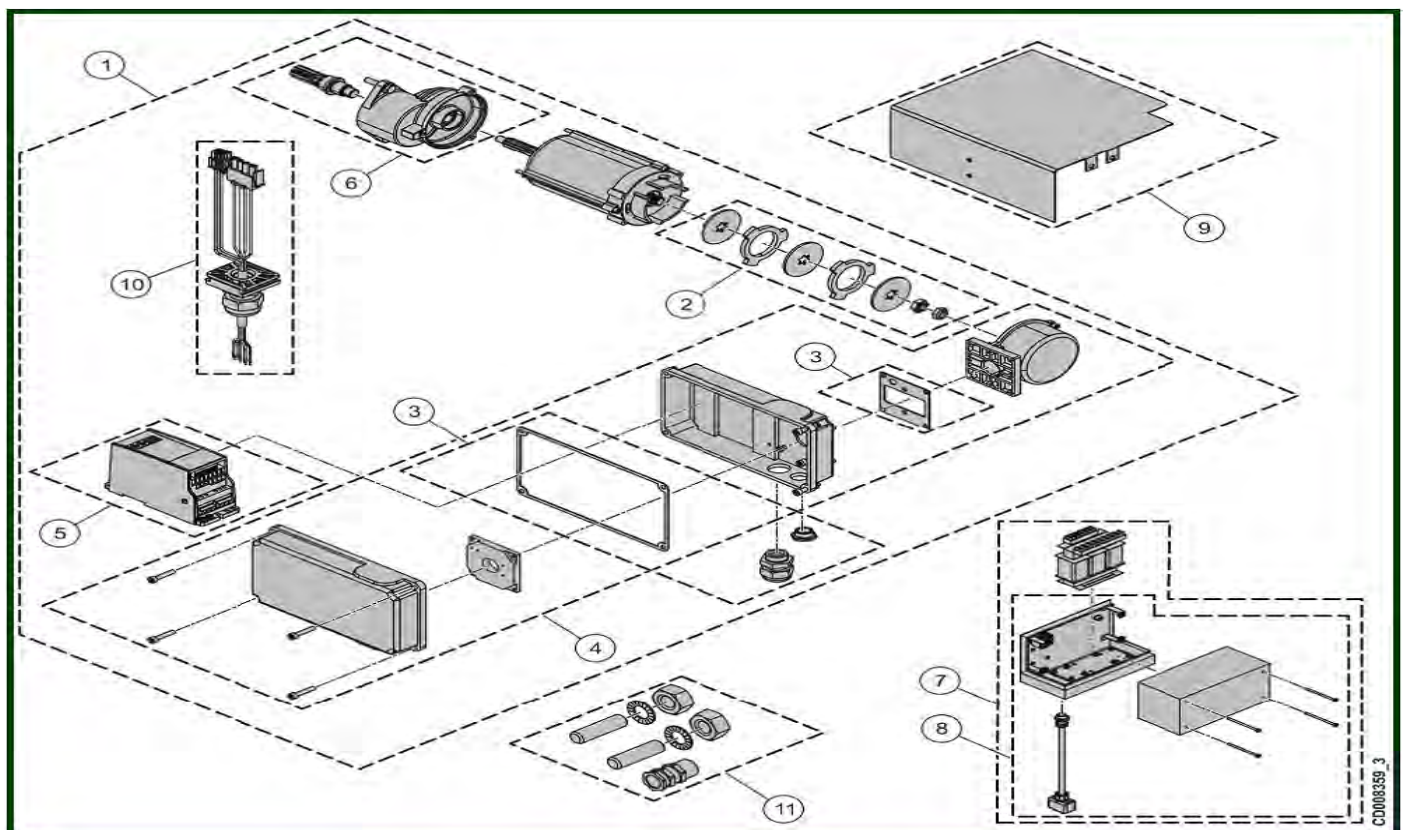



ITEM	REFERENCE	DESCRIPTION
1	52890308	Travelling machinery - TMU1, 42-230V < 1000 Kg
1	52890306	Travelling machinery - TMU2, 42-230V > 1000 Kg to 2000
2	52296293	Brake repair set, M06-001V
3	52300292	Sealing set, M06-008V
4	52907130	Housing set, M06-022V
5	52387783	Inverter VT003, TMK003.380 460V/ ctrl 42 230V, Since January 2015 for motor already equipped of this inverter
6	52297191	Reducer, GEL105PT1B0
7	52303806	Control panel, T50E-TE07
8	53050878	Housing set, UKTM/ALTM-NEW
9	52305058	Rain cover, All models C1 to C5
10	53110165	Connection Cable, TMU 1&2
11	52908158	Fixing set

### **8.3) TWO SPEED TMU MOTOR FOR VR HOIST**

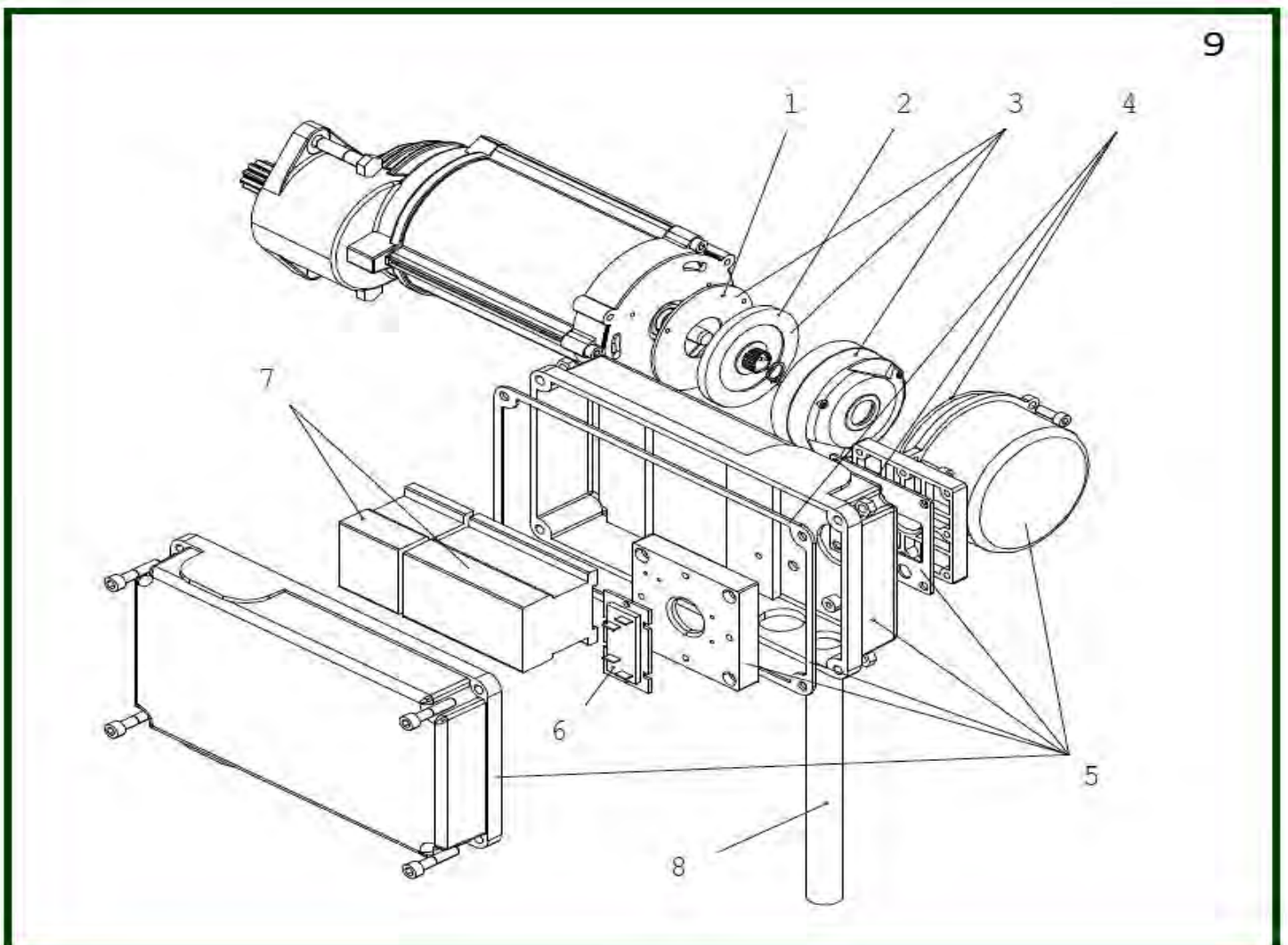



ITEM	REFERENCE	DESCRIPTION
1	52269590	Friction plate, NM38710KLV
2	52269587	Brake disc, NM38710JPV
3	52318378	Brake disc 180v, MF06MA104
3	52318416	Brake disc 240v dc, MF06MA104
3	52318424	Brake disc 290v, MF06MA104
4	52300292	Seal set, M06-008V
5	52300291	Terminal box, M06-007V
6	15823007	Rectifier, motor 220V
6	15823006	Rectifier, motors 380 to 550V
7	1113098	Main contactor KAU, 230V - 50-60 Hz
7	1123052	Reversing contactor, 110V
7	1113097	Reversing contactor, 230V
7	1113023	Reversing contactor - 400V-48V, LC2ECO9E (7531023V)
7	1113021	Selector contactor, 48V
7	1123050	Selector contactor, 110V
8	53110165	Connection Cable, TMU 1&2
9	52782175	TMU motor 2 speed, 230V/48V 50 Hz
9	52782176	TMU motor 2 speed, 400V/48V 50 Hz
9	52782171	TMU motor 2 speed, 460V/115V 60 Hz - Standard
9	52782177	TMU motor 2 speed, 500V/48V 50 Hz
9	52782172	TMU motor 2 speed, 575V/115V 60 Hz - Standard
-	52782173	TMU motor 2 speed, 230V/115V 60 Hz - Standard
-	52305058	Rain cover, All models C1 to C5

#### **8.4) CHAIN TRAVEL**

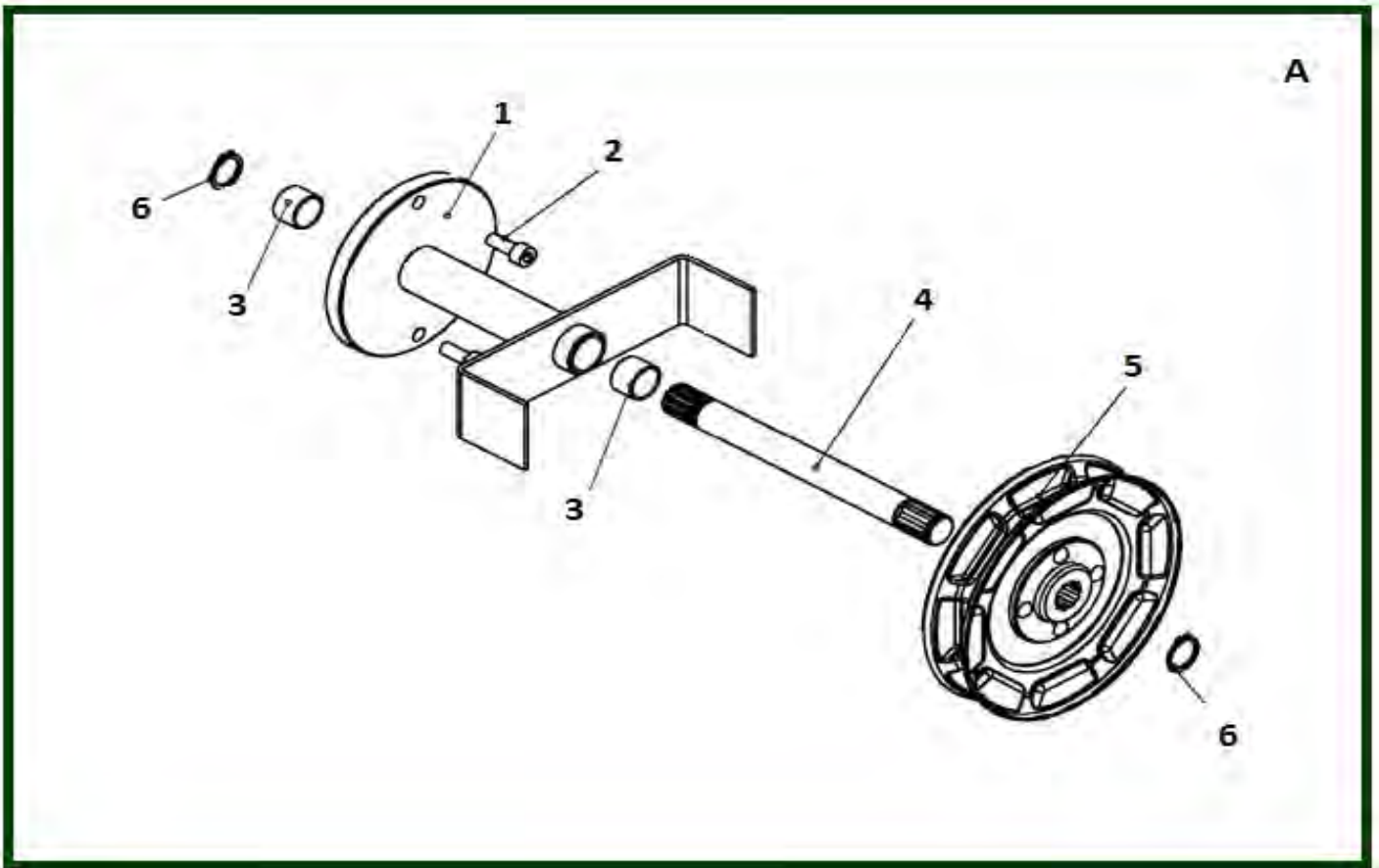

ITEM	REFERENCE	DESCRIPTION
1	52306328	Support
2	830905	CHC Screw 8X20
3	993275	Bearing
4	52306329	CHM shaft
5	400953	Travelling hand wheel - Ø 165 mm, 3,2T
6	400052	Circlips
-	820003	Galvanized hand chain - 5x27,1
-	53020194	Hand chain - 5x27.1, 9,8 meters
A	52306332	Chain operated manual travelling, For C1 to C5

## 8.5) RIGHT ANGLE MOTOR

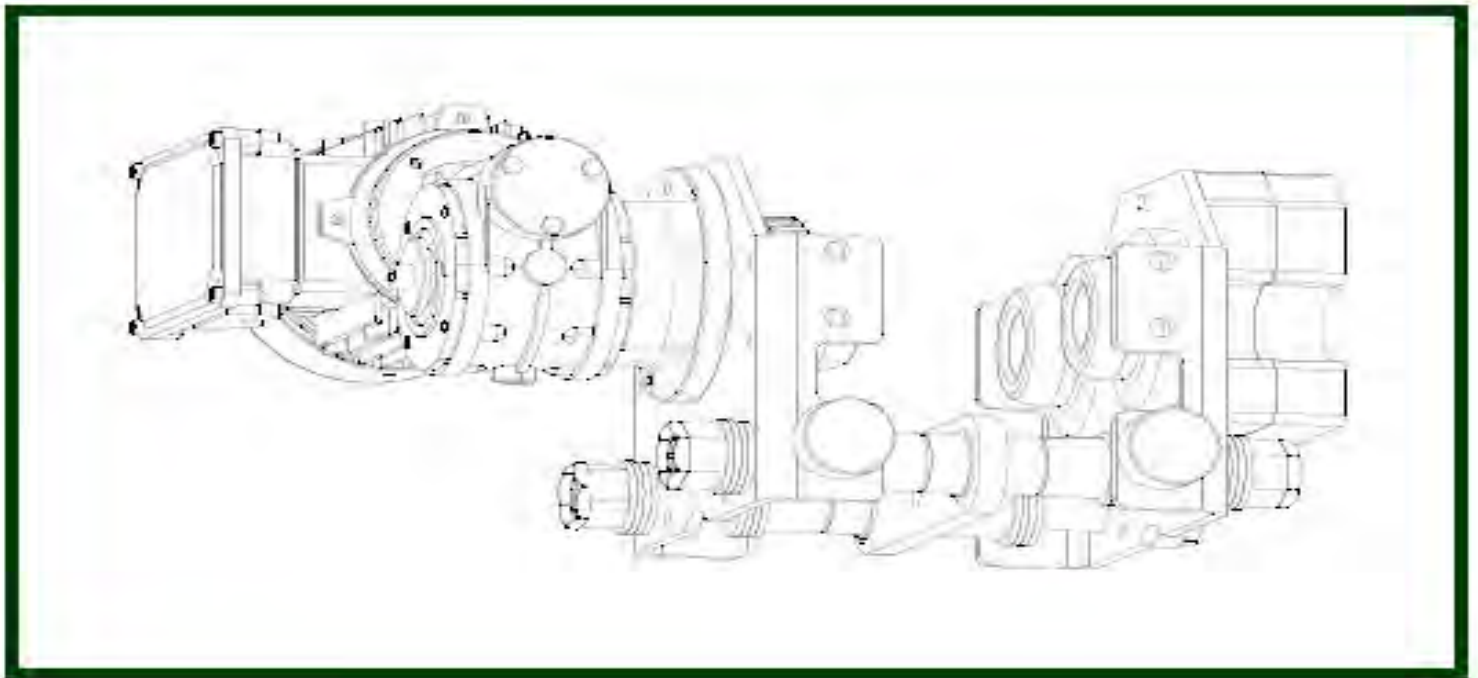

ITEM	REFERENCE	DESCRIPTION
-	551037	Cubicle + Mac2 pcb
-	2216904	Adaptation set for right angle travelling machinery, Pinion, flange, screws
-	2133033	CI board, 2VD/2CS MAC
-	556972	Right angle travelling machinery, speed 10 & 2.5m/min - for C1-C2-C3

## 9) LOW HEADROOM TROLLEY

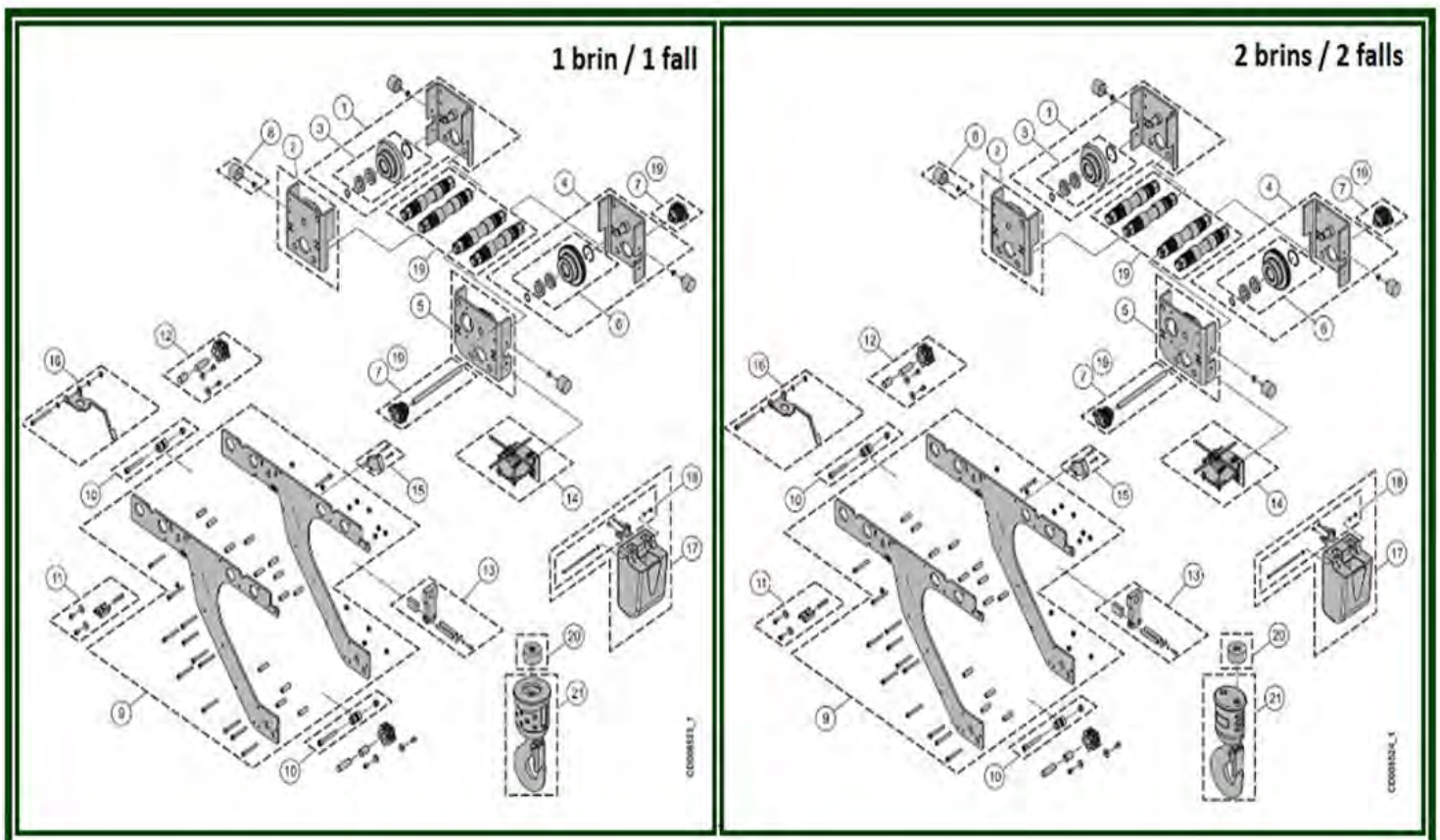

## 9.1) LHT - 1 FALL

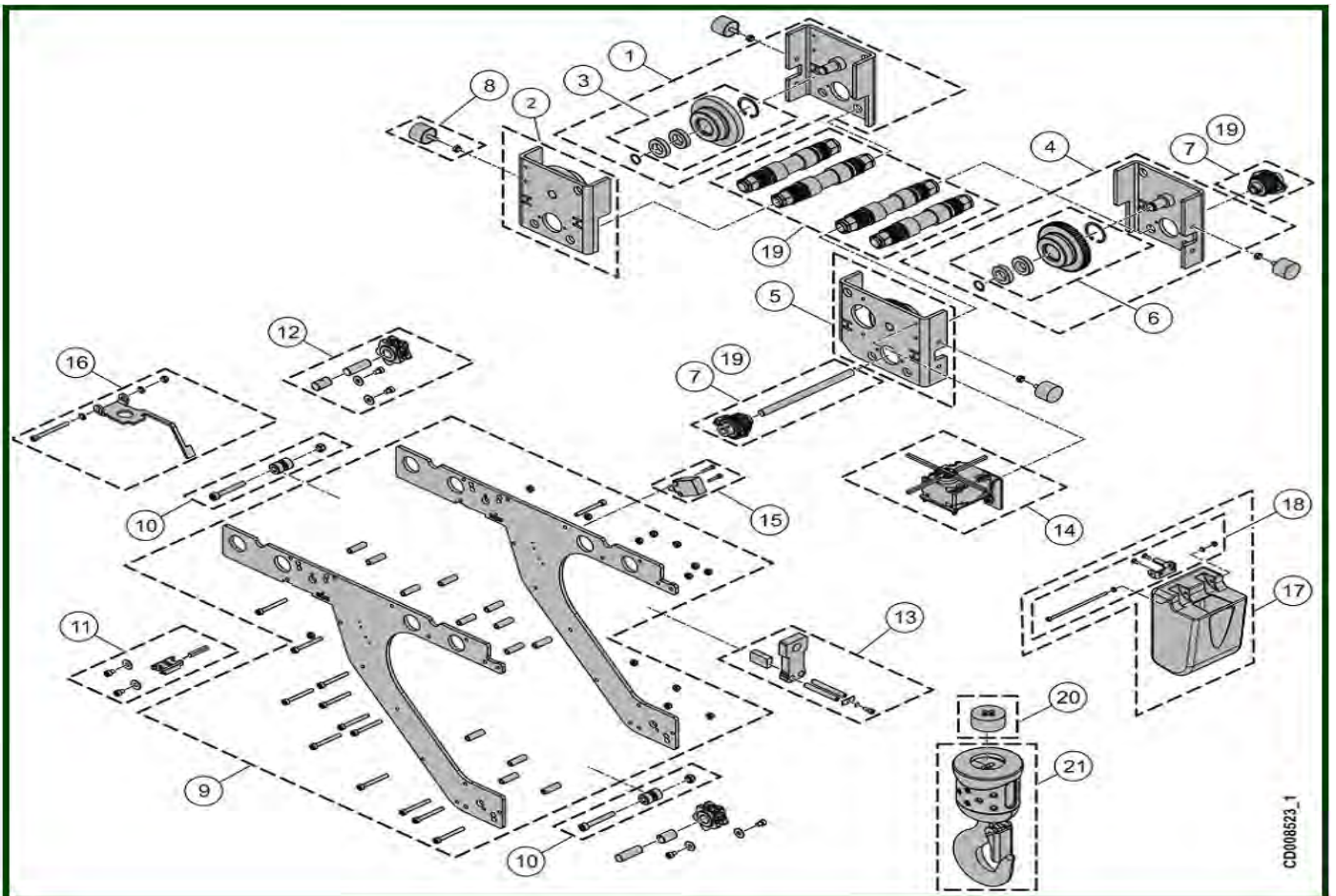

ITEM	REFERENCE	DESCRIPTION
1	VT0008742	Idle flange
2	VT0008743	Idle flange, Motor side
3	VT0008961	Travel wheel idle without shaft
4	VT0008745	Motor flange, Motor side
5	VT0008746	Motor flange, Motor side
6	VT0008963	Travel wheel without shaft
7	VT0008748	Gear wheel set - 66 to 112, L232
7	VT0008947	Gear wheel set - 113 to 154, L274
7	VT0008948	Gear wheel set - 155 to 199, L315
7	VT0008949	Gear wheel set - 200 to 259, L362
7	VT0008950	Gear wheel set - 260 to 300, L422
8	VT0008749	Buffer, D40 L50
9	VT0009137	Plate set - LHT
10	VT0009138	Diabolo set, HPR / LHT
11	VT0009161	Fixing set, 4x11,7
12	VT0009162	Chain sprocket, 4x11,7



13	VT0009163	Suspension, L237 W56,5H56
14	VT0008756	Limit switch, 1 step
15	VT0009187	Limit switch assembly - LHT
16	VT0009140	Limit switch activator, HPR / LHT
17	VT0009105	Chain bucket, 6 m for 4x11
17	VT0009106	Chain bucket, 16 m for 4x11
17	VT0009107	Chain bucket, 35 m for 4x11
18	VT0009108	Fixing set of chain bucket, D6L151
19	VT0009141	Shaft set - 66 to 112, L232
19	VT0009142	Shaft set - 113 to 154, L274
19	VT0009143	Shaft set - 155 to 199, L315
19	VT0009144	Shaft set - 200 to 259, L362
19	VT0009145	Shaft set - 260 to 300, L422
20	VT0007576	Rubber chain stop - New model, since 17/06/2015
21	VT0009129	Hook block, Standard

## 9.2) LHT - 2 FALLS

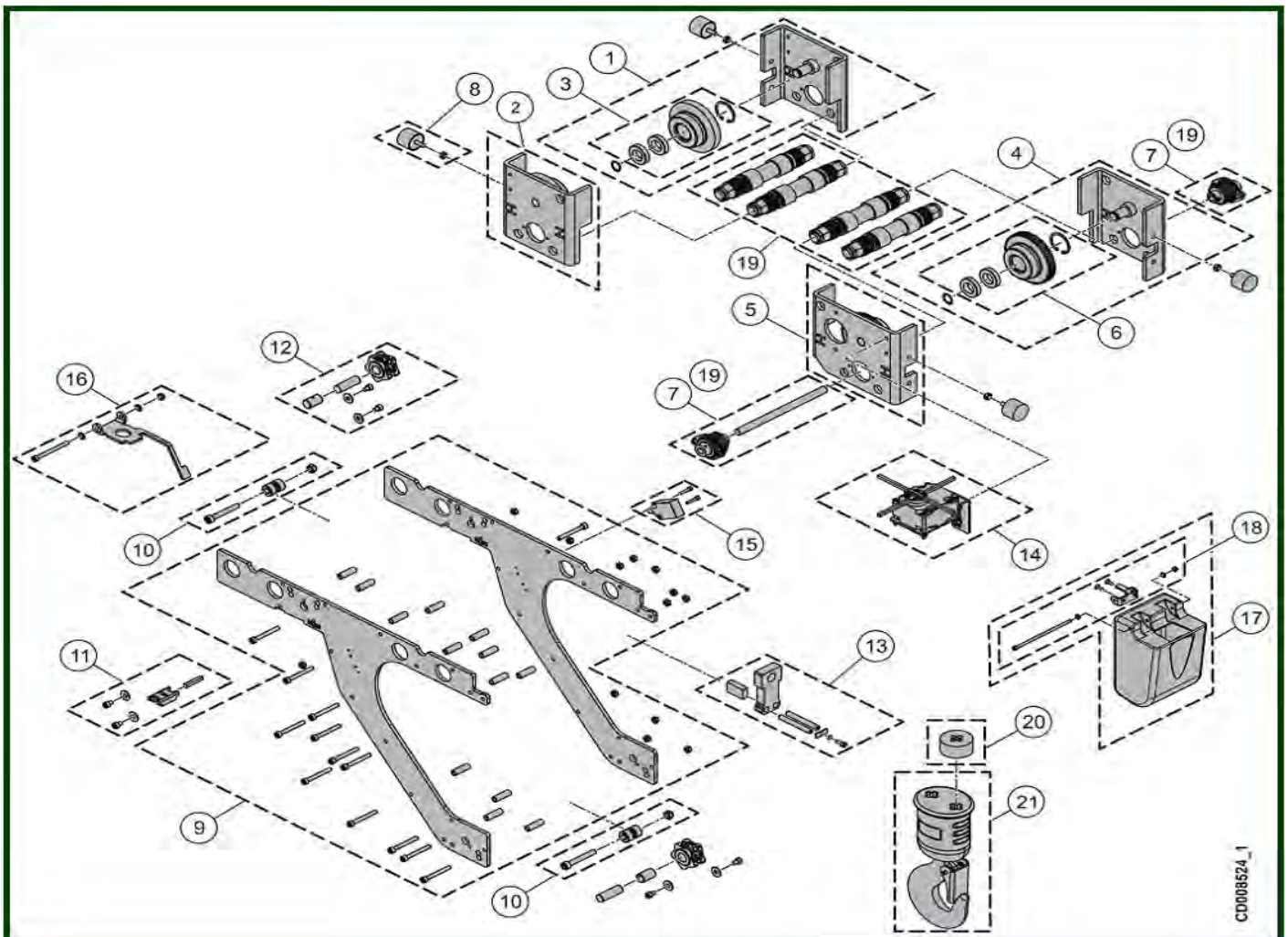

ITEM	REFERENCE	DESCRIPTION
1	VT0008742	Idle flange
2	VT0008743	Idle flange, Motor side
3	VT0008961	Travel wheel idle without shaft
4	VT0008745	Motor flange, Motor side
5	VT0008746	Motor flange, Motor side
6	VT0008963	Travel wheel without shaft
7	VT0008748	Gear wheel set - 66 to 112, L232
7	VT0008947	Gear wheel set - 113 to 154, L274
7	VT0008948	Gear wheel set - 155 to 199, L315
7	VT0008949	Gear wheel set - 200 to 259, L362
7	VT0008950	Gear wheel set - 260 to 300, L422
8	VT0008749	Buffer, D40 L50
9	VT0009137	Plate set - LHT
10	VT0009138	Diabolo set, HPR / LHT
11	VT0009161	Fixing set, 4x11,7
12	VT0009162	Chain sprocket, 4x11,7
13	VT0009163	Suspension, L237 W56,5H56
14	VT0008756	Limit switch, 1 step
15	VT0009187	Limit switch assembly - LHT
16	VT0009140	Limit switch activator, HPR / LHT
17	VT0009105	Chain bucket, 6 m for 4x11
17	VT0009106	Chain bucket, 16 m for 4x11
17	VT0009107	Chain bucket, 35 m pour/for 4x11
18	VT0009108	Fixing set of chain bucket, D6L151
19	VT0009141	Shaft set - 66 to 112, L232
19	VT0009142	Shaft set - 113 to 154, L274
19	VT0009143	Shaft set - 155 to 199, L315
19	VT0009144	Shaft set - 200 to 259, L362
19	VT0009145	Shaft set - 260 to 300, L422
20	VT0007576	Rubber chain stop - New model, since 17/06/2015
21	VT0009101	Hook block - 2 falls, Standard hook + Standard hook block

## 10) MANUAL TROLLEY CHD



ITEM	REFERENCE	DESCRIPTION
-	VT0006536	Buffer, Ø 18mm - 250 kg
-	VT0006537	Buffer, Ø 24mm - 500 kg