

SPARE PARTS CATALOGUE - SM5 OLD

To avoid errors, when ordering please specify:

- Complete type of hoist
- Date of manufacture and serial number
- Spare part code
- Spare part designation
- Additional information

0) DESCRIPTION

1) HOISTING MOTOR AND CASING

2) MECHANISM AND BRAKE

2.1) Specific part - Double brake

3) LIFTING ASSEMBLY

4) ELECTRIC CUBIC FOR A VERSION

0) DESCRIPTION

Load capacity Capacité de charge	Type of hoist Type de palan	Models Modèles	Number of falls Nombre de brins	Type of chain Type de chaîne
125 Kg	SM5 124M2	D	1	4.8 x 12.5
	SM5 128M2			
250 Kg	SM5 254M2	A,B,C,D,E		
	SM5 258M2			
	SM5 2516M1			
500 Kg	SM5 504M1	A,B,C,E		
	SM5 508M1			
	SM5 504M2	D		



Version inversée A (standard) ou versions B,C,D,E

Inverted version A (std) or versions B,C,D,E (inverted option)



Version normale B,C,D,E (std) ou version A (option)

Normal : version B,C,D,E (std) or version A (option)

1) HOISTING MOTOR AND CASING

(*) Used for single speed/ - 8m/mn 1 fall or 4m/mn 2 falls

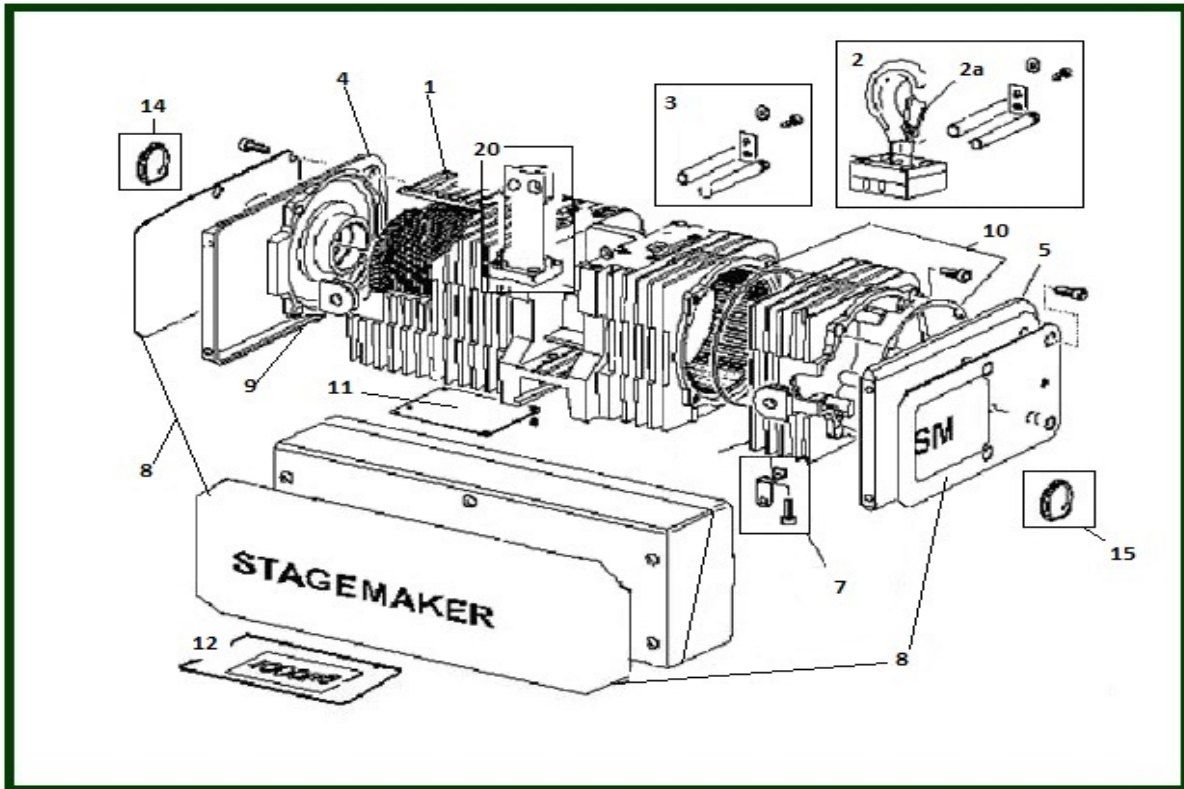

ITEM	REFERENCE	DESCRIPTION
1	2219965	Housing assembled with gear rim and stator 230V/50Hz
1	2219967	Housing assembled with gear rim and stator 230V/60Hz
1	2219964	Housing assembled with gear rim and stator 400V/50Hz-460V/60Hz
1	2219966	Housing assembled with gear rim and stator 400V/60Hz
1	2219968	Housing assembled with gear rim and stator 500V/50Hz-575V/60Hz
1	2209964	Housing assembly/gear rim/ stator / loadwheel 400V/50Hz-460V/60Hz
1	2219970	Housing assembled with stator and gear 230V/50Hz - 1 speed
1	2219969	Housing assembled + stator & gear 400V/50Hz-460V/60Hz-1 speed
1	2219974	Housing assembled + stator & gear 500V/50Hz-575V/60Hz-1 speed
2	52316782	Rotating hook assembly kit Type A or (B,C,D,E)
2a	2212017	Safety latch - Steel plate type 1 Fall
3	2257020	Hook suspension shaft set
4	2219961	End cap assembly - Motor side M6 screw + Cap
5	2219962	End cap assembly - Brake side Vis / Counterweight + screws
6	2210007	Brake cap assembly
7	2218000	Button box fastening bracket

8	2216047	SM5 stickers and covers set
9	2218004	Cable guide
10	2218006	Sealing ring and O-ring for brake cap
11	2216520	Motor data plate (Only if serial number is provided)
12	2219938	Set of 10 load plates – Hoist 125 kg
12	2219918	Set of 10 load plates – Hoist 250 kg
12	2219920	Set of 10 load plates – Hoist 500 kg
14	2218001	Plastic plug
15	52283279	Cap - Brake side
-	52334562	Canvas rain cover

2) MECHANISM AND BRAKE

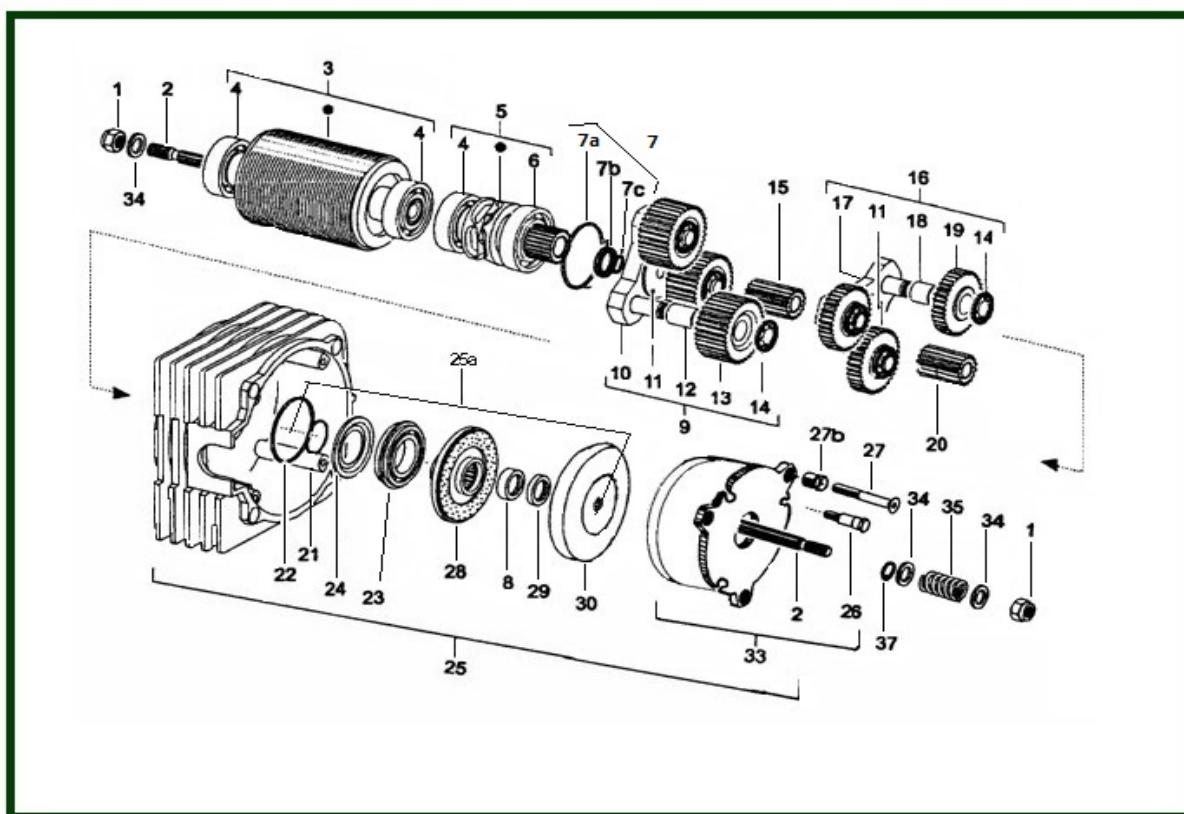

ITEM	REFERENCE	DESCRIPTION
2	2211501	Gear input shaft
3	2215000	Rotor assembly – •+4+4 2 speed
3	2215001	Rotor assembly – •+4+4 single speed
4	833713	Bearing
5	2214001	Chain sprocket assembled •+4+6
7	2219983	Gear sealing set
9	2210520	Planet gear assembly - 2nd step 10+11+12+13+14 - 16 m/min

9	2210500	Planet gear assembly - 2nd step 10+11+12+13+14 – 8 m/min
15 - 20	2210503	Pinion tem 15 / 2nd step
16	2210510	Planet gear assembly - 1st step 11+14+17+18+9
25	2211071	Brake limiter, assembly + housing 100 VDC - 220V - 230V
25	2211070	Brake limiter, assembly + housing 190 VDC 380V - 460V
25	2211072	Brake limiter, assembly + housing 240 VDC 500V - 575V
25a	2219984	Metal sealing ring set and brake disc 21+22+23+ 24+28+8+29+30
30	2211020	Brake disk
33	2211080	Brake with fittings 100 V
33	2211081	Brake with fittings 190 V
33	2211082	Brake with fittings 240 V
33	2211083	Brake with fittings 330V – 690V
-	2211016	Clutch spring set
-	2218009	Sealing set 22+23+24+29+37

2.1) SPECIFIC PART - DOUBLE BRAKE

For other parts, refer C05 standard doc/Note: use black AS312 loctite between first & second brake housing)

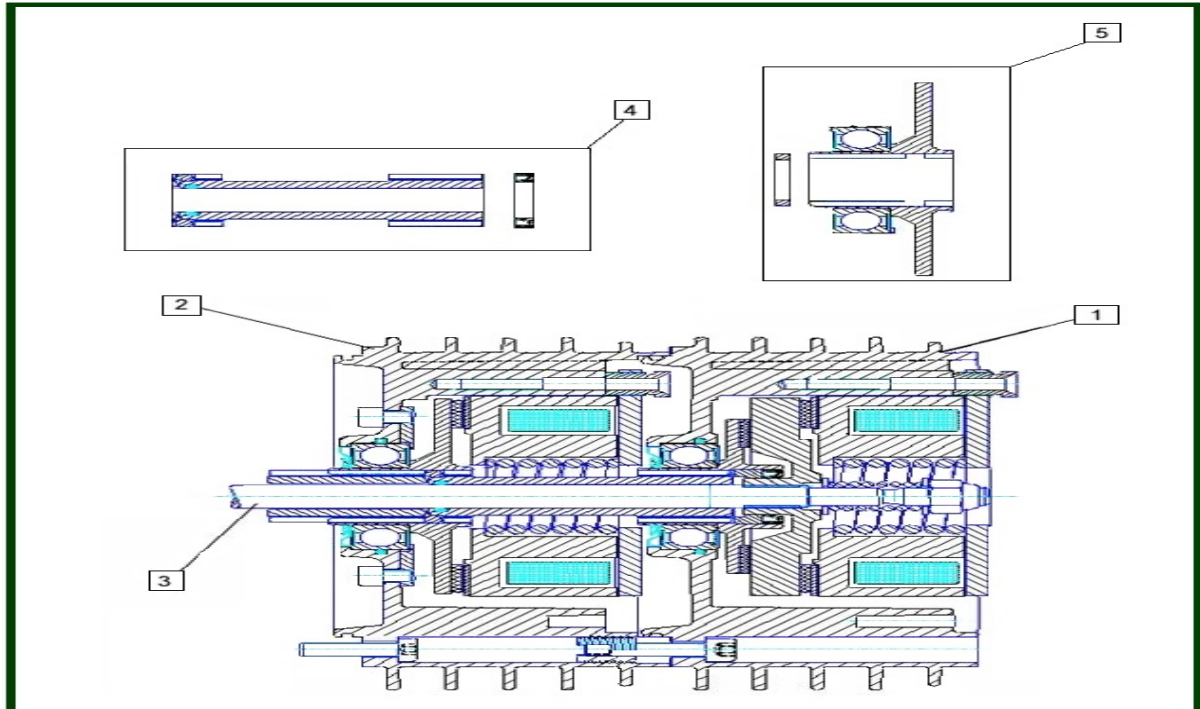

ITEM	REFERENCE	DESCRIPTION
1	2219017	First brake limiter assembly with housing 100VDC
1	2219007	First brake limiter assembly with housing 190VDC
2	2219008	First brake limiter assembly with housing 190VDC

2	2219018	Second brake assembly with housing 00VDC
3	2219051	Double brake motor shaft
4	52316873	Coupling pinion set
5	52316872	Friction disc assembly for second brake
-	2219058	Metal electric box
-	52316874	Seal set

3) LIFTING ASSEMBLY

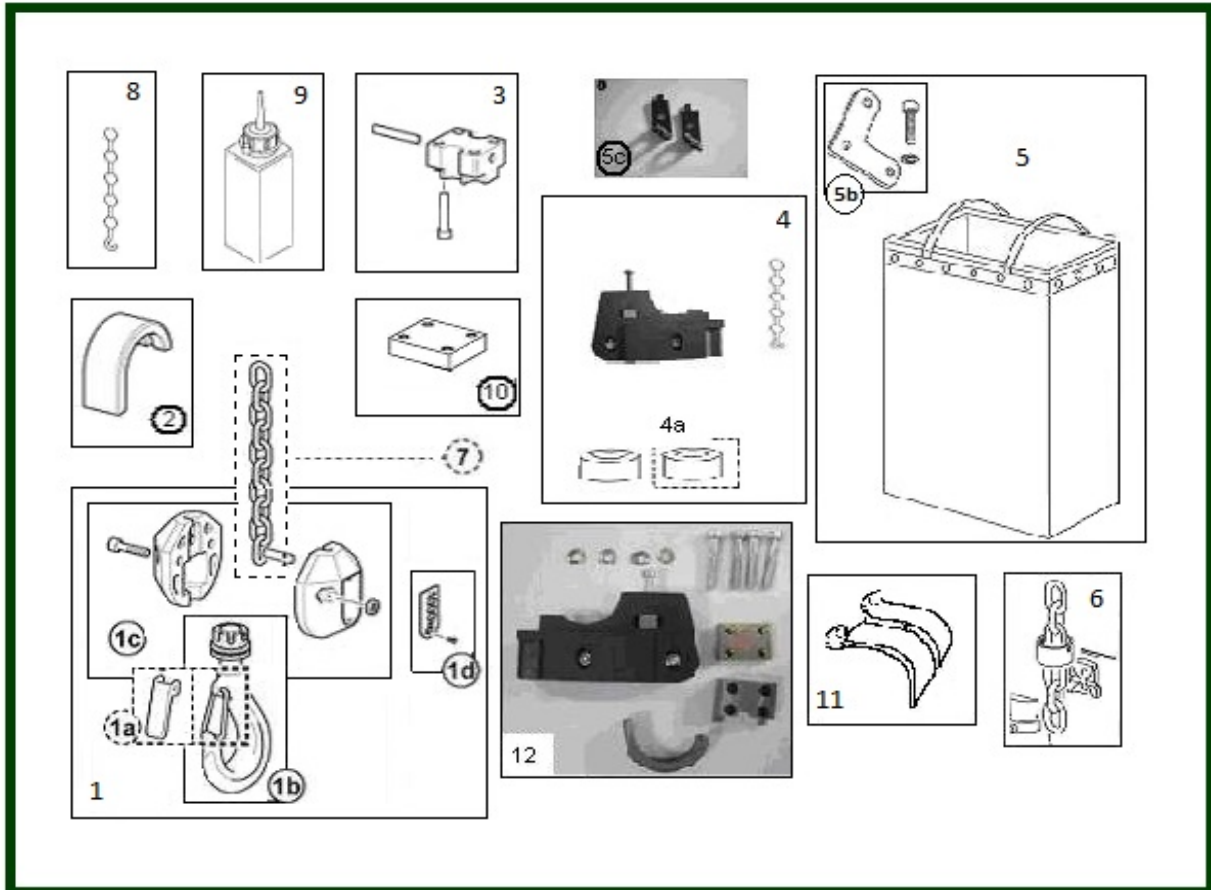

ITEM	REFERENCE	DESCRIPTION
1	52293142	Fall lifting hook block - Standard type
1a	2212017	Safety latch - Steel plate type – single fall
1b	2257006	Fall lifting hook - Standard type
1c	52318801	Set of 2 half-casings with axle and screws
1d	2219937	Set of 10 load plates - 1 fall 125kg
1d	2219907	Set of 10 load plates - 1 fall 250kg
1d	2219909	Set of 10 load plates - 1 fall 500kg
2	2214011	Upper chain guide
3	2213523	Chain anchor assembly

4	52311106	lower chain guide set +buffers
4a	52305498	Rubber buffer (2)
5	52311223	Chain bag - 40 m with carabiner version A
5	52328054	Chain bag - 50 m With carabiner version A/1 (B,C,D,E)
5b	52306044	Fixing plate set with carabiner version A
5c	2257019	Fixing plate set for old chain bag
6	2211050	Slack fall stop assembly
7	52322933	Load chain - Black type 4.8x12.5
8	2211045	Load chain mounting tool
9	9995008	Can of oil for chain for chain 125ml
10	2213521	Fix point for hoist 2/1 - Only to modify the hoist 2/1
12	52300195	Repairing kit for SM5 When lugs on housing are broken

4) ELECTRIC CUBIC FOR A VERSION

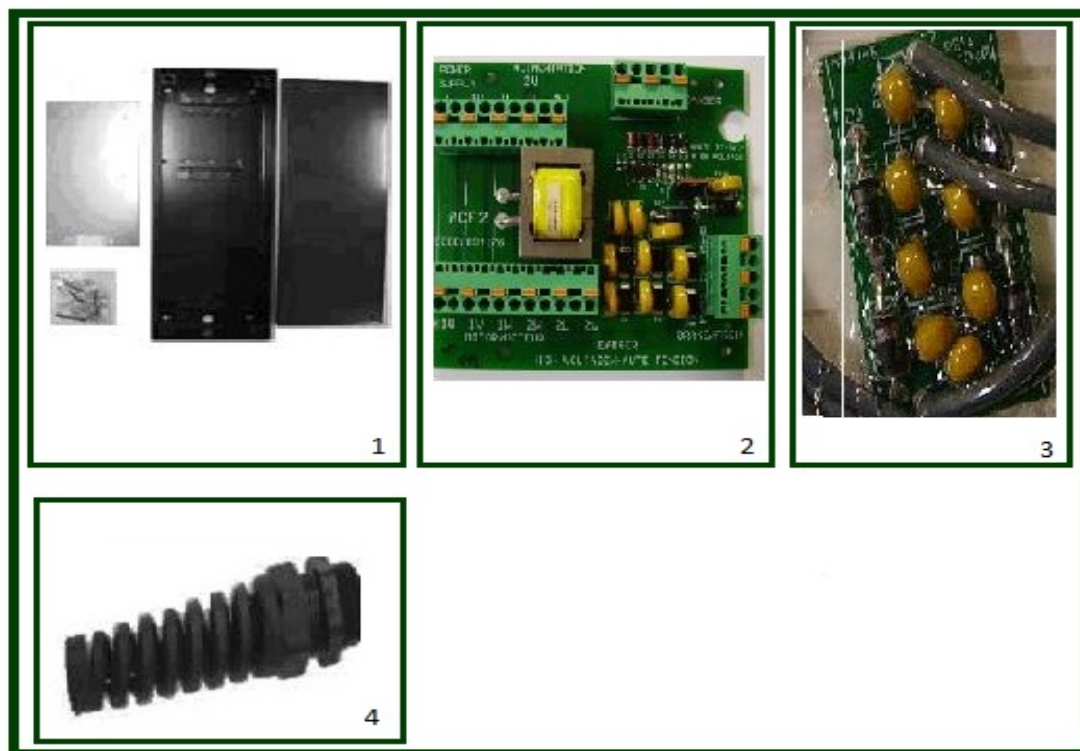

ITEM	REFERENCE	DESCRIPTION
1	52307758	SM5 Metal electrical cubicle-A type hoist (direct voltage) to 4/10/2004
2	834176	ACF PC Board - For A type hoist (direct voltage)
3	2243060	Std rectifier-230-575V-C05-C25 hoist /Stagemaker E type (direct volt)
4	52283994	Spiral cable gland
-	52292671	Red power supply plug 3P+ E - For A type hoist